

PLANVENDOSJA E DEPOS
SH 1:200

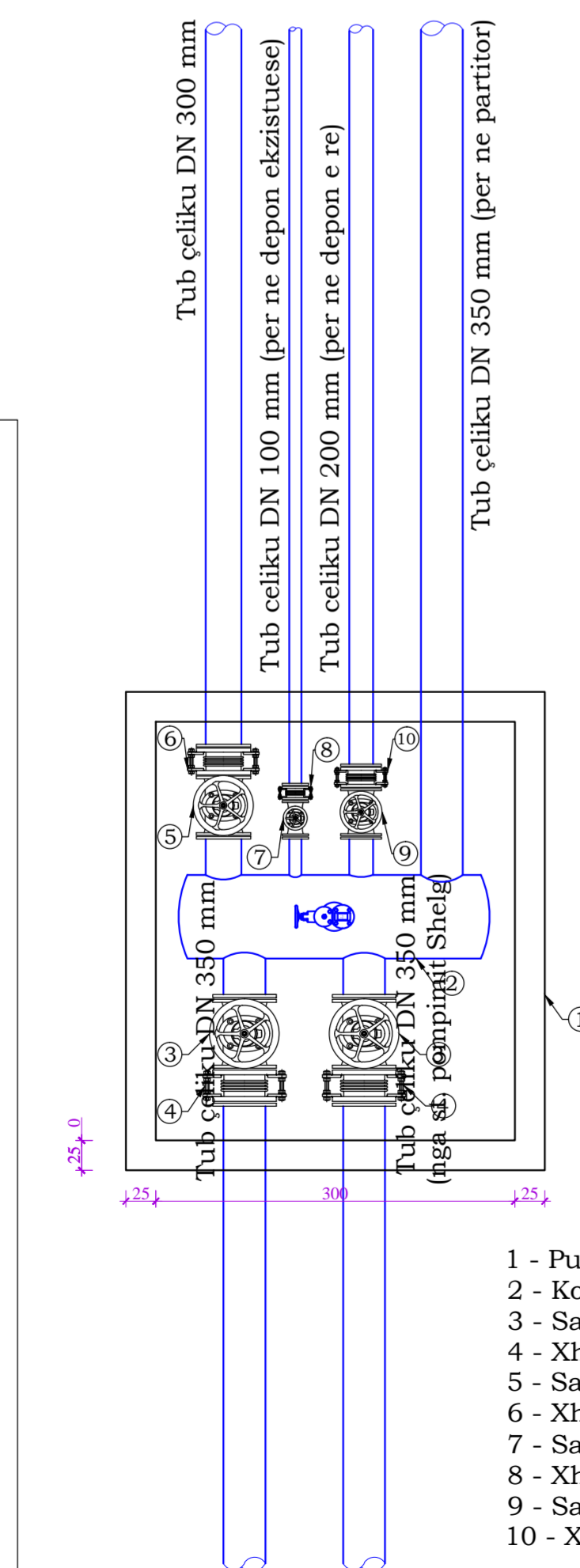

PUSETE KRYESORE KOMANDIMI



- 1 - Pusete manovrimi (3.0 x 3.5)m
- 2 - Kolektor çeliku DN 700 mm
- 3 - Saracineske DN 350 mm, PN10
- 4 - Xhunto zmontimi DN 350 mm
- 5 - Saracineske DN 300 mm, PN10
- 6 - Xhunto zmontimi DN 300 mm
- 7 - Saracineske DN 700 mm, PN10
- 8 - Xhunto zmontimi DN 100 mm
- 9 - Saracineske DN 200 mm, PN10
- 10 - Xhunto zmontimi DN 200 mm

DHOME MANOVRIMI DEPO 1000 M3

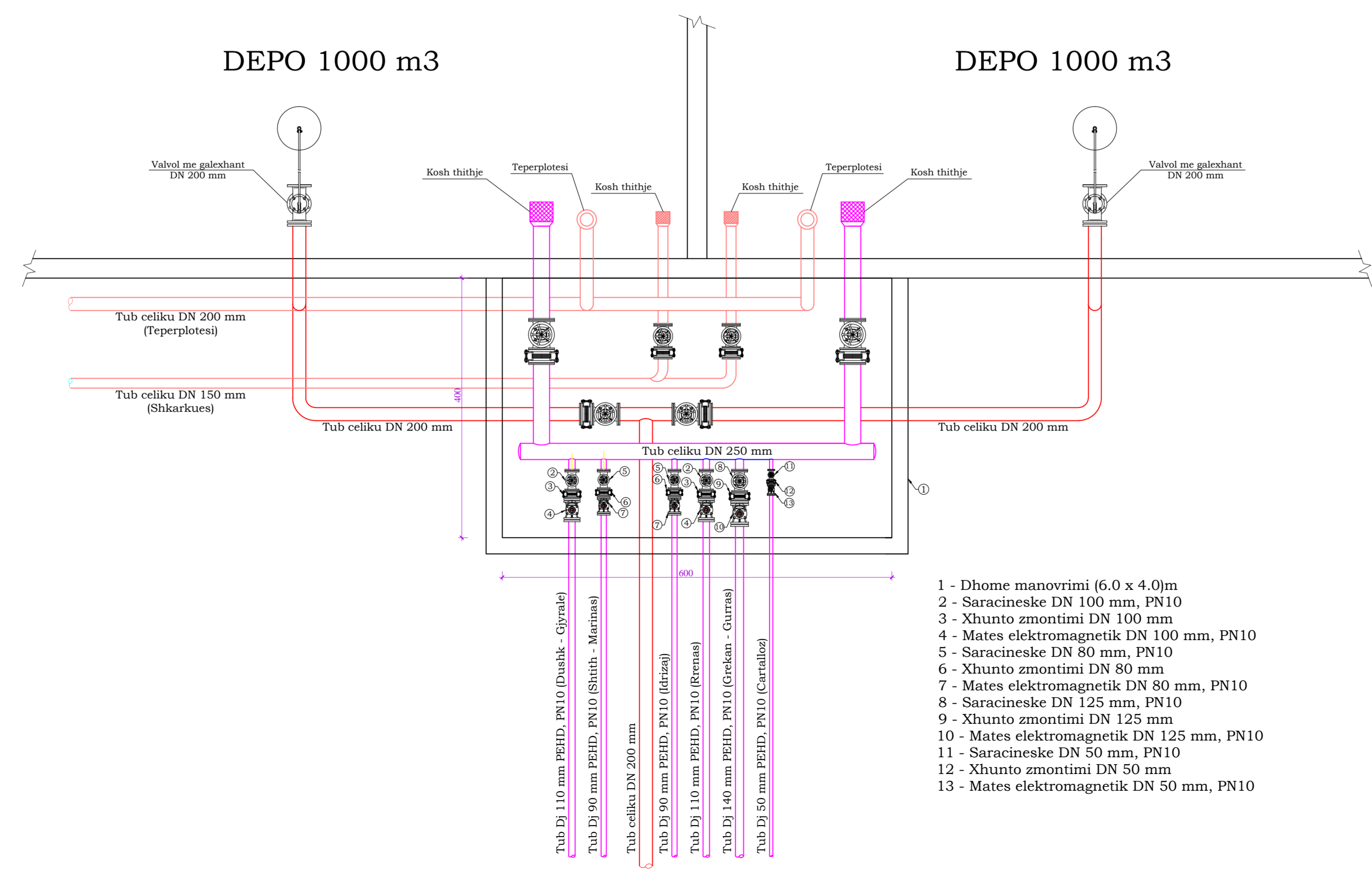

PARAQITJE SKEMATIKE
SHPERNDARESIS GASTARE

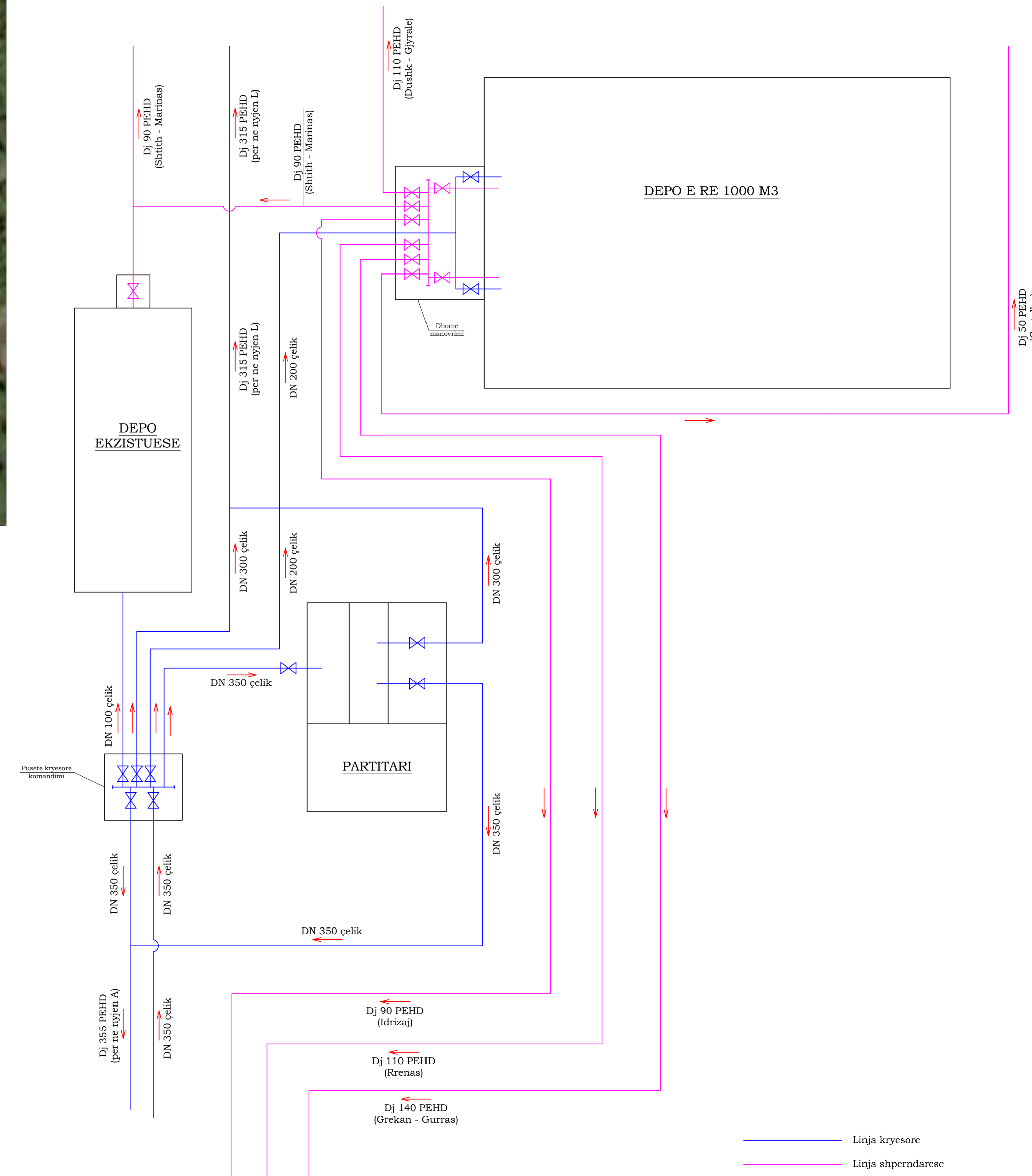

- Linja kryesore
- Linja shperndarese

"SPHAERA" sh.p.k
PROJEKTIM
SUPERVIZION
KOLAUDIM

Rruga "QAZIM VATHI" nr 106 Tirane
Mobile: 00355 69 20 38848
e-mail: ajkidtopore@sphaera.al
ajkidtopore@yahoo.com
website: www.sphaera.al

REPUBLIKA E SHQIPERISE
Ministria e Puneve Publike Transportit dhe Telekomunikacionit
DREJTORIA E PERGJITHSHME
E UJESJELLESIT DHE KANANIZIMEVE

**RIKONSTRUKSION I RRJETIT TE UJESJELLESIT RAJONAL
TE ZONES SE DUMRESE
RRETHI ELBASAN**

Titulli i vizatimit:
01. DEPO (SHPERNDARES) GASTARE

**PLANVENDOSJE / SKEMA E SHPERNDARESIT
DHE PUSETAT SHOQUERUESE TE DEPOS**

FALA E PROJEKTE	PROJEKT ZBATIMI	DATA	PRILL 2013
NUMRI I VIZATIMIT	PL_D-01A	SHKALLA	1:50, 1:200
PUNOJ	Ing. Ajkid Topore	PERPUNOJ	Ing. Eljo Kamberaj
	Ing. Hysni Ruka		
	Ing. Andi Xhelepi		

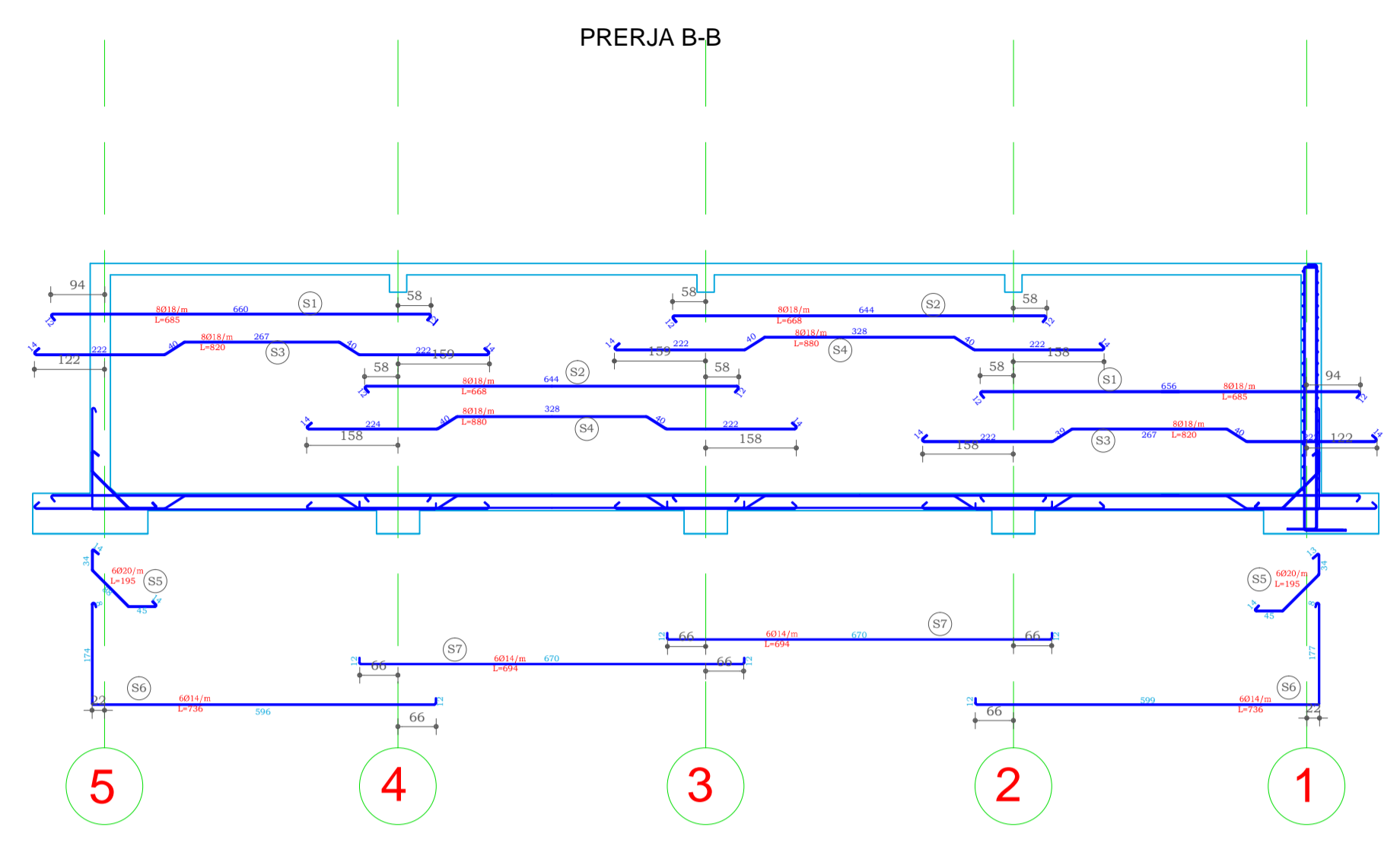
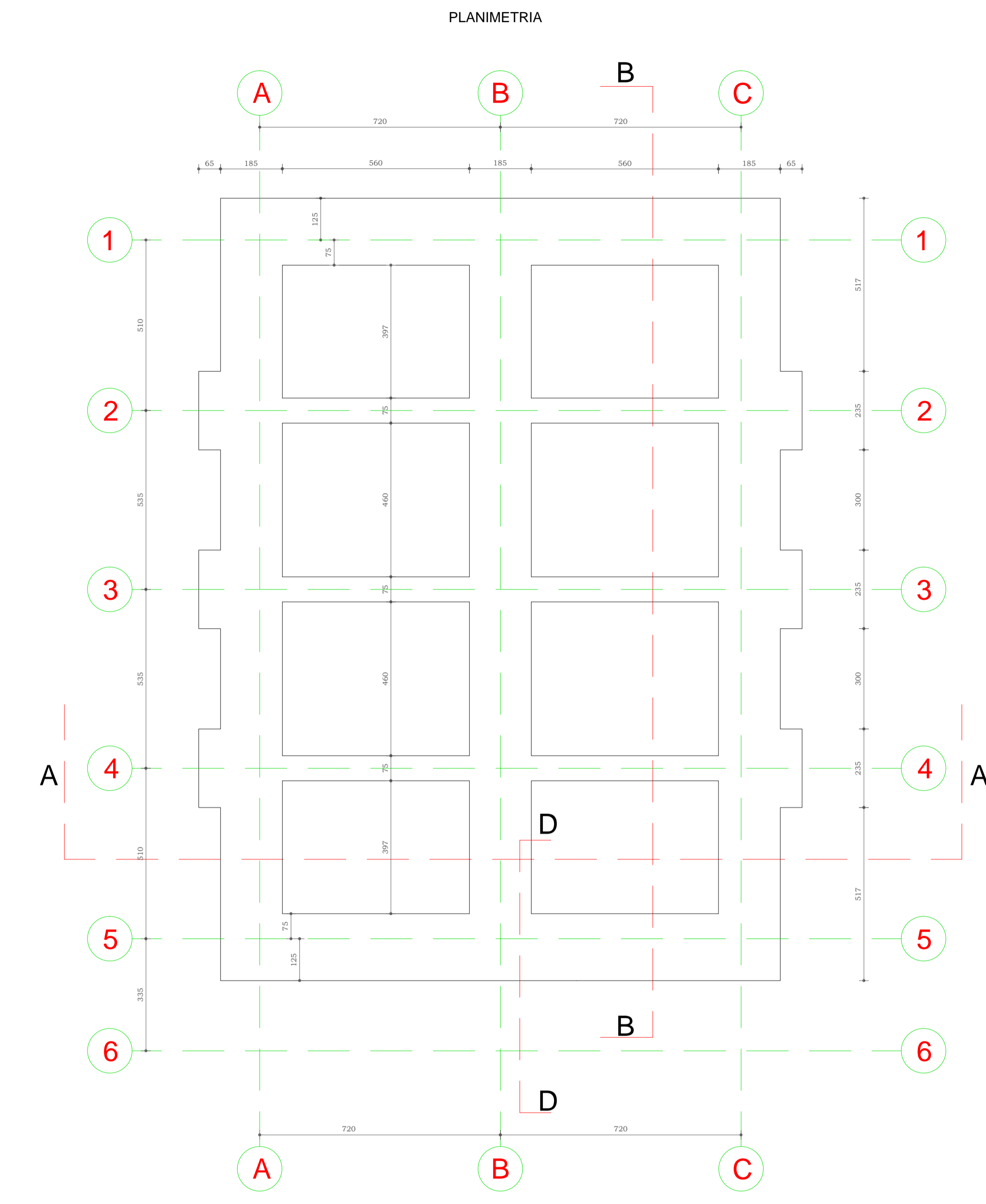
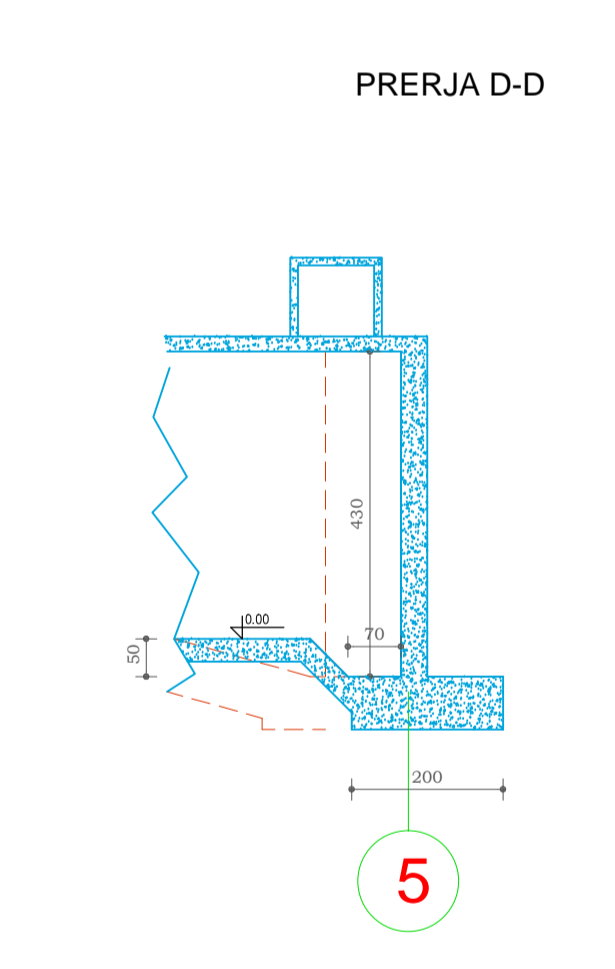
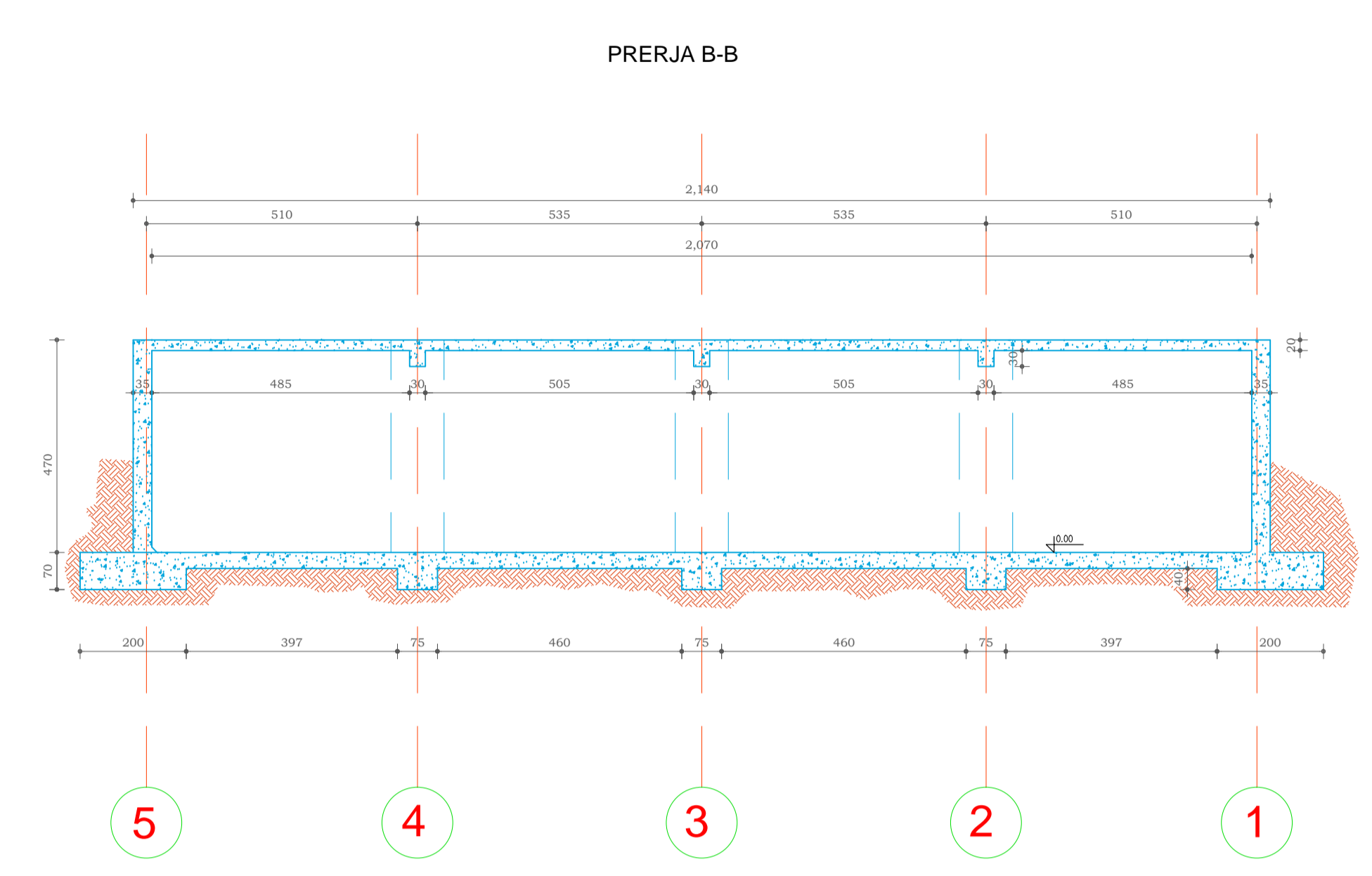
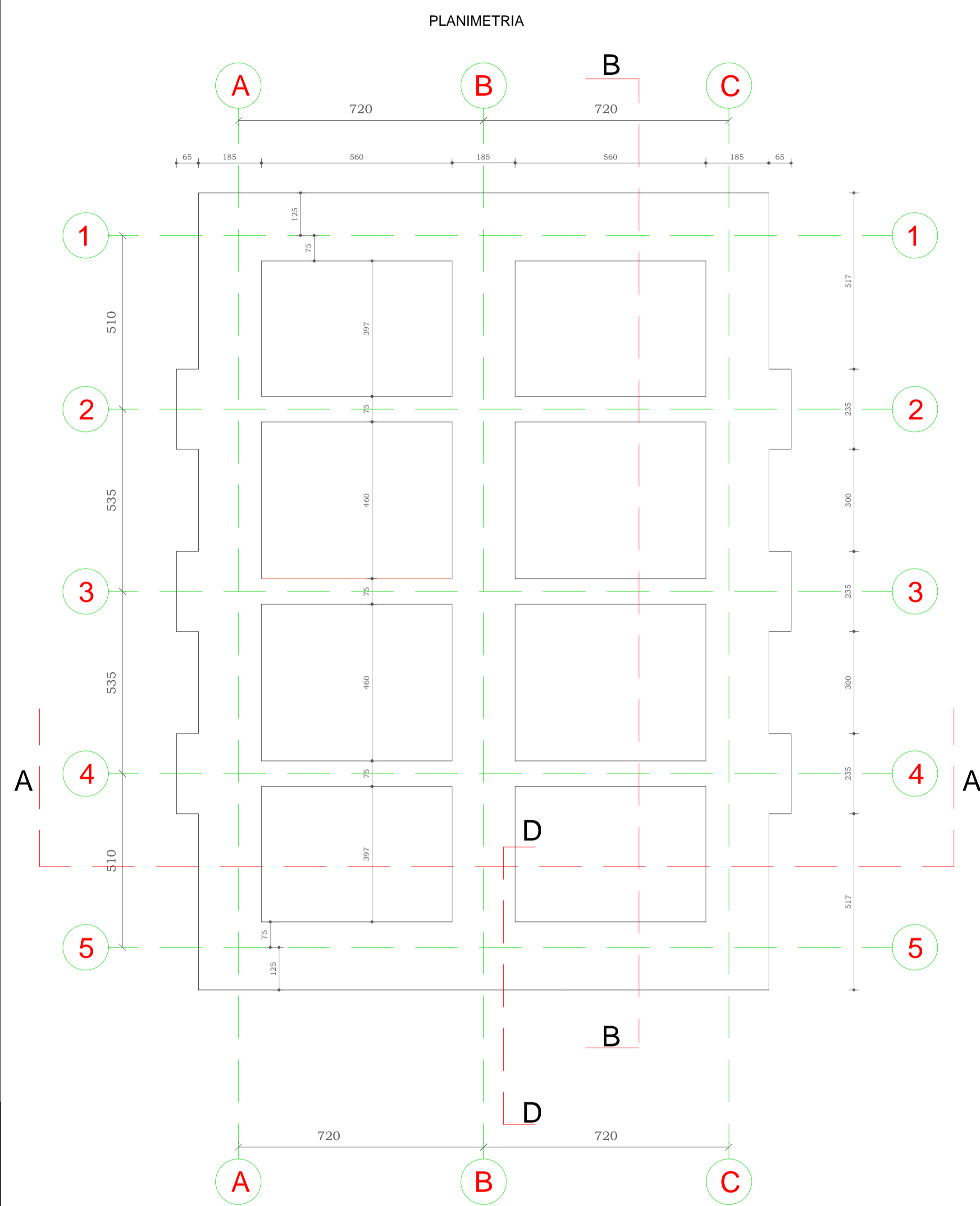

TOTALI SIPAS B-B					
SHIFRA	Ø	COPE	GAJTESIA (M)	GAJTESIA TOT (M)	PERIJA (M)
B1	Ø18	224	6.85	1356	3032
B2	Ø18	224	6.85	1356	3032
B3	Ø18	224	6.30	1260	2820
B4	Ø18	224	6.30	1260	2820
B5	Ø20	224	1.95	437	1016
B6	Ø14	224	2.36	548	1227
B7	Ø14	224	6.94	1354	3024

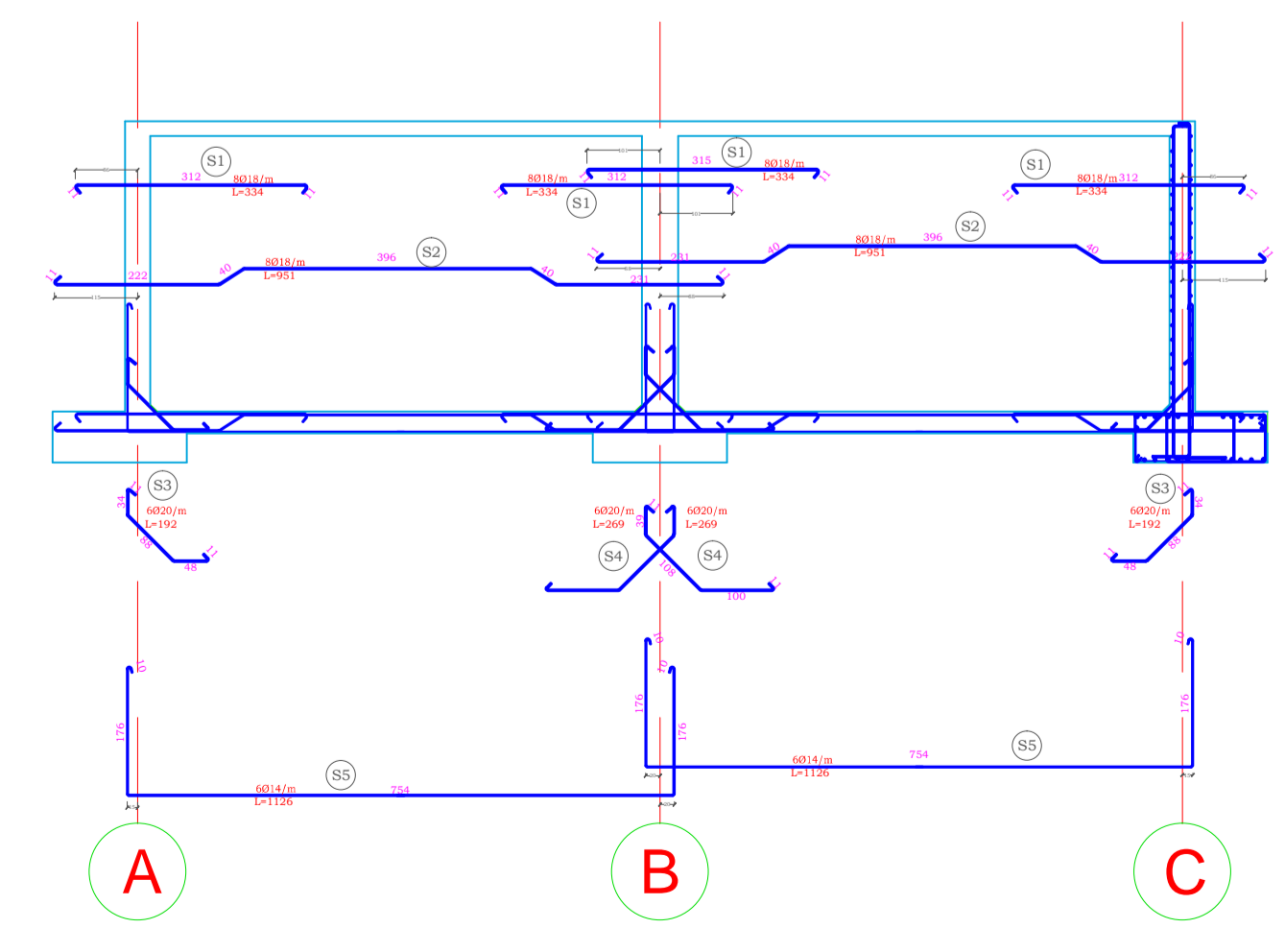
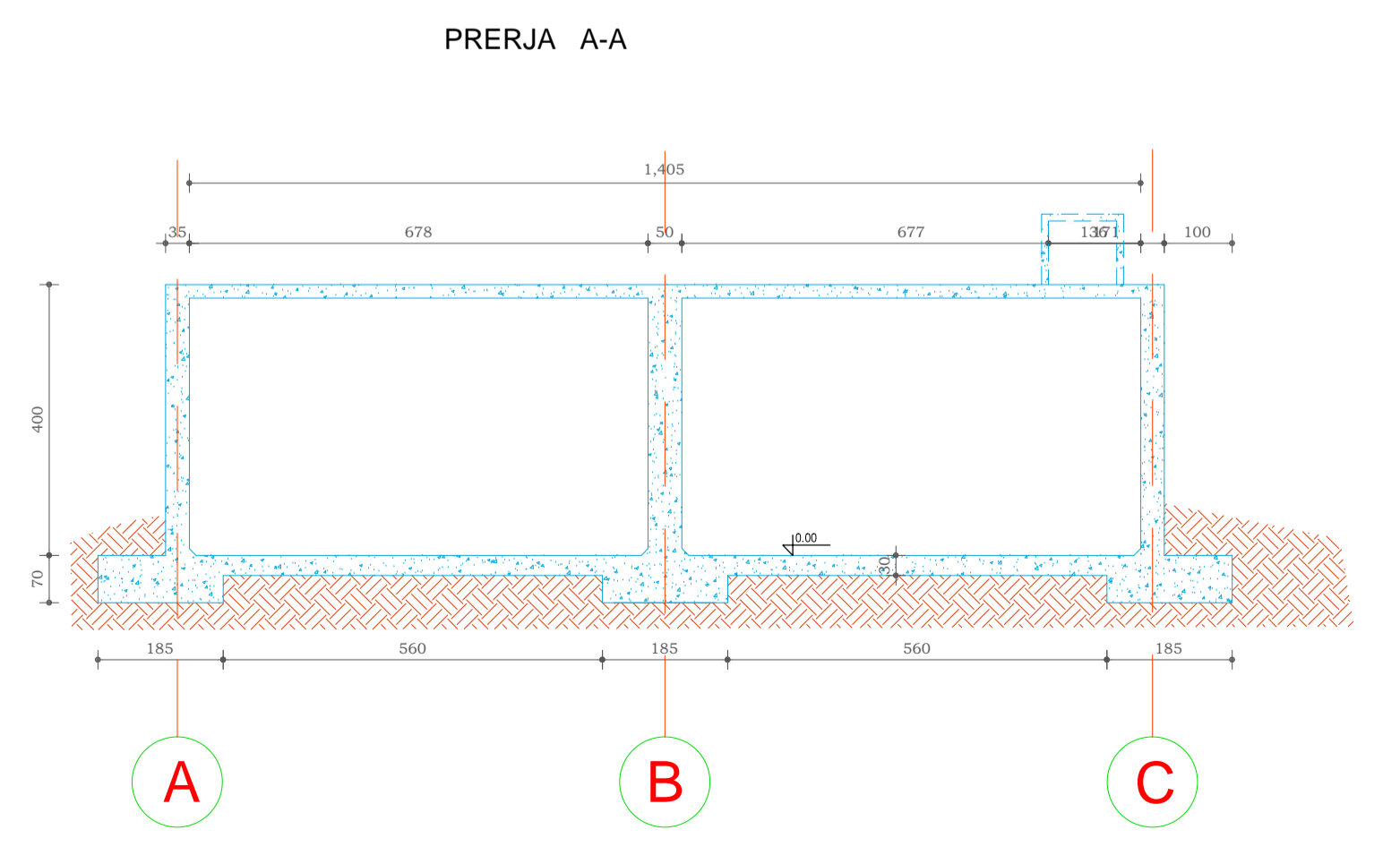

BETON 120m3

TOTALI SIPAS A-A					
SHIFRA	Ø	COPE	GAJTESIA (M)	GAJTESIA TOT (M)	PERIJA (M)
B1	Ø18	440	3.34	1137	2523
B2	Ø18	320	9.31	3041	6655
B3	Ø20	320	1.92	614	1472
B4	Ø20	320	3.69	961	2094
B5	Ø14	320	11.26	3603	7920

"SPHAERA" sh.p.k
 Rruga "QAZIM VATHI" nr 106 Tirane
 PROJEKTIM
 SUPERVIZION
 KOLAUDIM
 Mobile: 00355 69 20 38848
 e-mail: ajkidtopore@sphaera.al
 ajkidtopore@yahoo.com
 website: www.sphaera.al

REPUBLIKA E SHQIPERISE
 Ministria e Punesve Publike Transportit dhe Telekomunikacionit
 DREJTORIA E PERGJITHSHME
 E UJESJELLESIT DHE KANANIZIMEVE

RIKONSTRUKSION I RRJETIT TE UJESJELLESIT RAJONAL
 TE ZONES SE DUMRESE
 RRETHI ELBASAN

Titulli i vizatimit:
 01. DEPO (SHPERNDARES) GASTARE
 ARMIMI I DEPOS fleta 1

FAZA/PROJEKTI	PROJEKT ZBATIMI	DATA	PRILL 2013	Ing. Ajkid Topore
NUMRI I VIZATIMIT	PL_D-01B	SHKALLA	1:100	Punoi Ing. Hysni Ruka Ing. Anri Xhielepi Përpunoi Ing. Edo Kamberaj

"SPHAERA" sh.p.k
 PROJEKTIM
 SUPERVIZION
 KOLAUDIM

Mobile: 00355 69 20 38848
 e-mail: ajkidtopore@sphaera.al
 ajkidtopore@yahoo.com
 website: www.sphaera.al

REPUBLIKA E SHQIPERISE
 Ministria e PUNEVE Publike Transportit dhe Telekomunikacionit
 DREJTORIA E PERGJITHSHEME
 E UJESJELLESIT DHE KANANIZIMEVE

RIKONSTRUKSION I RRJETIT TE UJESJELLESIT RAJONAL
 TE ZONES SE DUMRESE
 RRETHI ELBASAN

Titulli i vizatimit:
 01. DEPO (SHPERNDARES) GASTARE
 ARMIMI I DEPOS fleta 2

PROJEKT ZBATIMI
 DATA: PRILL 2013
 Ing. Ajkid Topore
 Punoi Ing. Hysni Ruka
 Ing. Anad Xhielepi
 Përpunoi Ing. Ejo Kamberaj

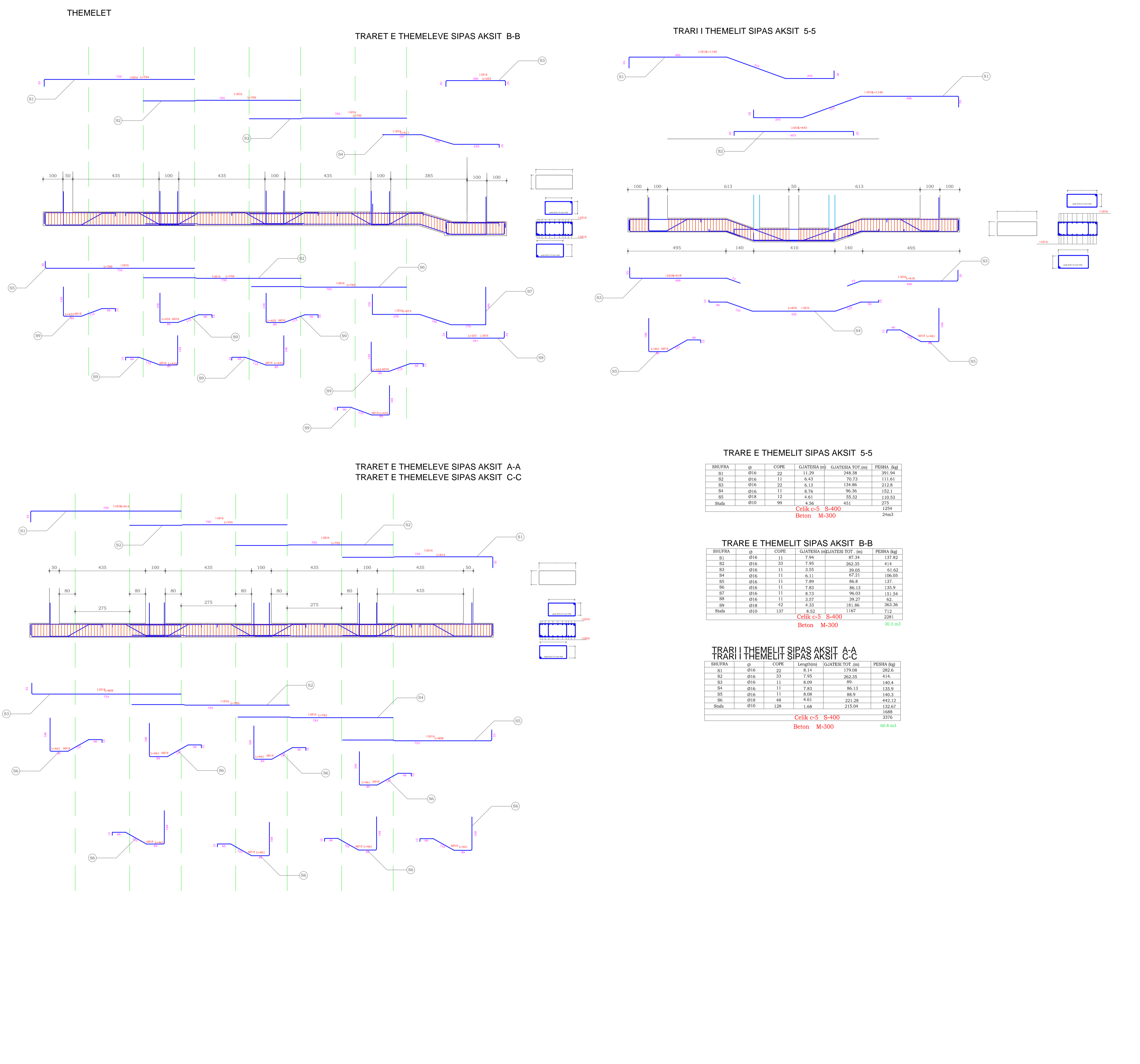
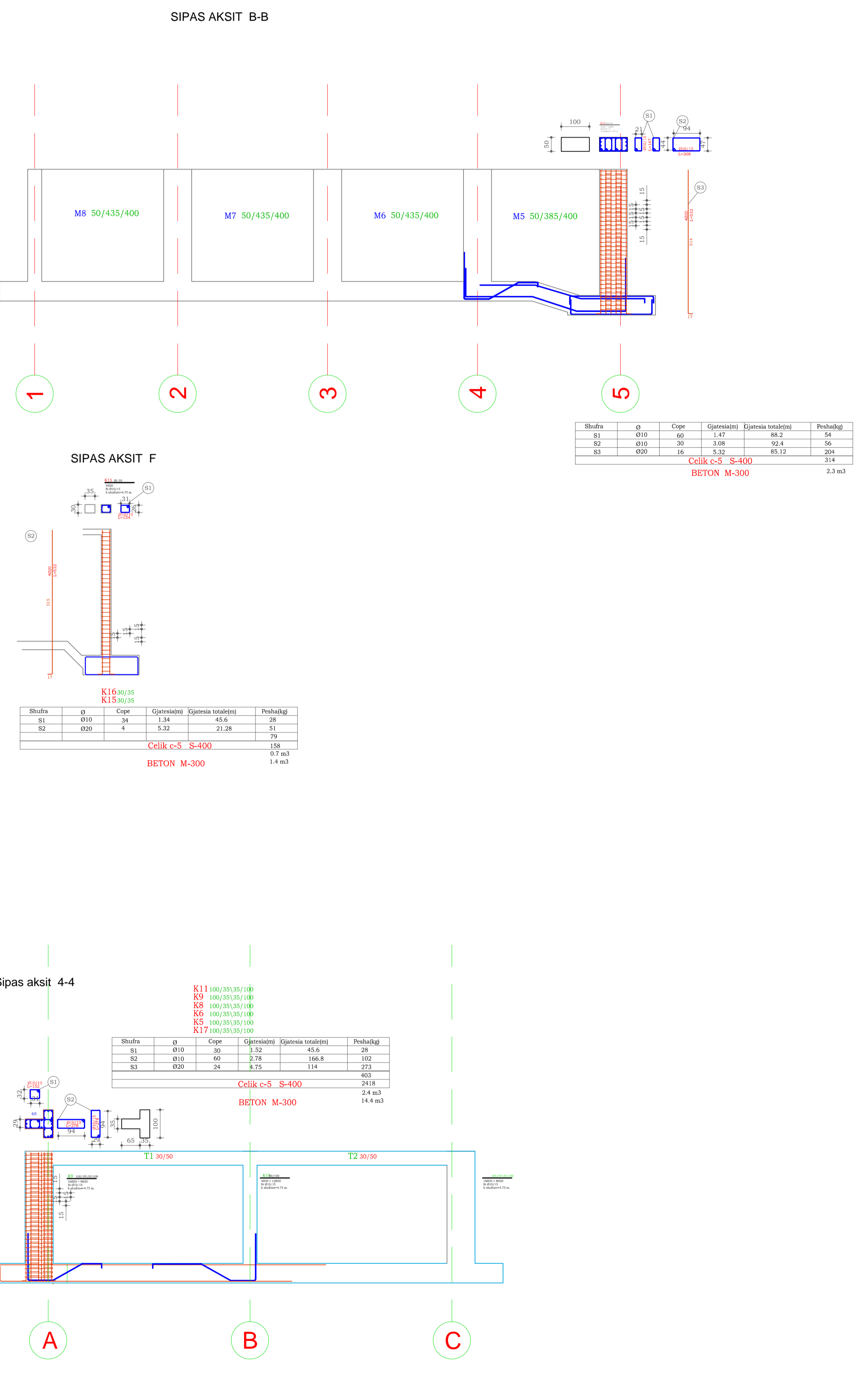
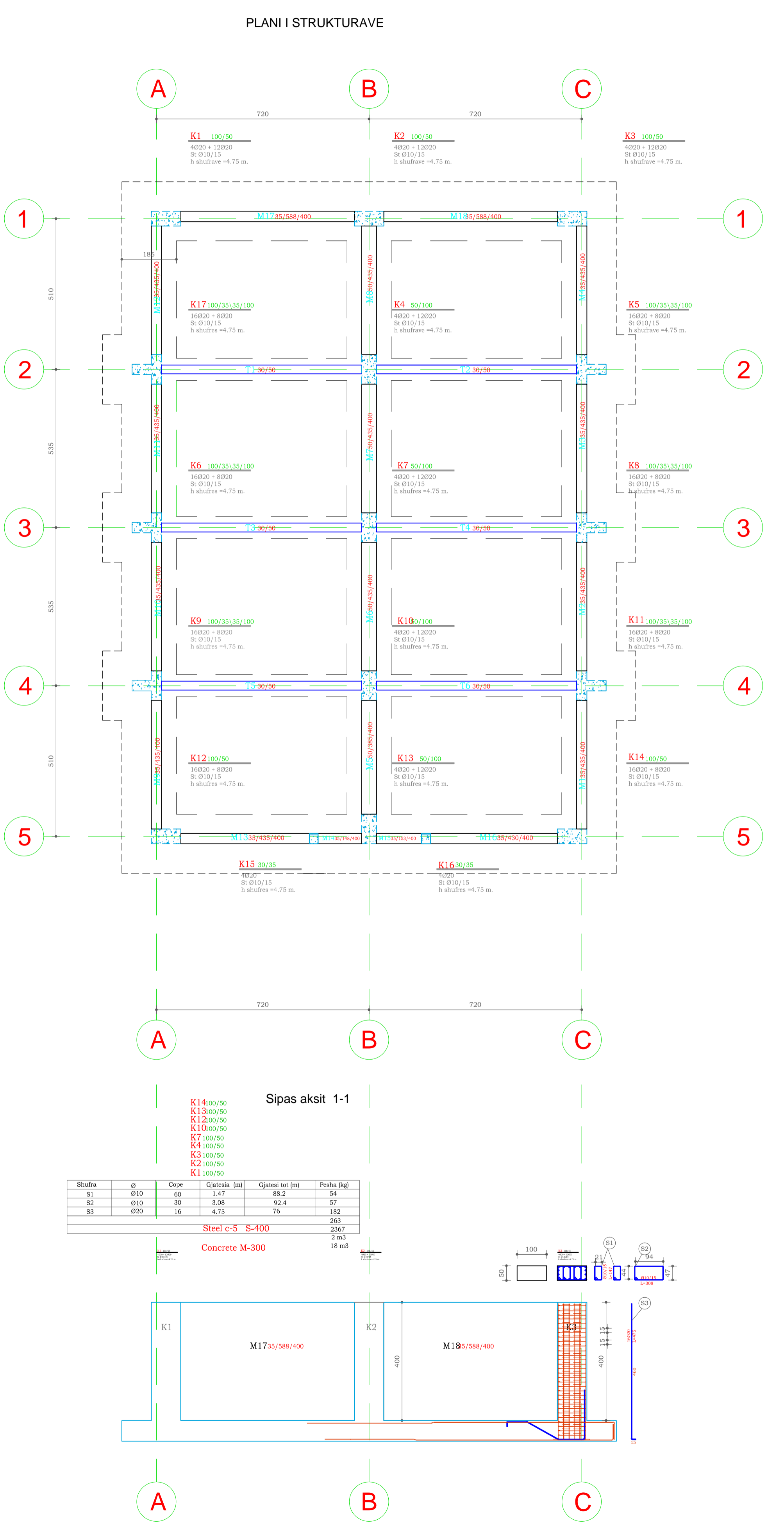

TRARET E THEMELIT SIPAS AKSIT 1-1

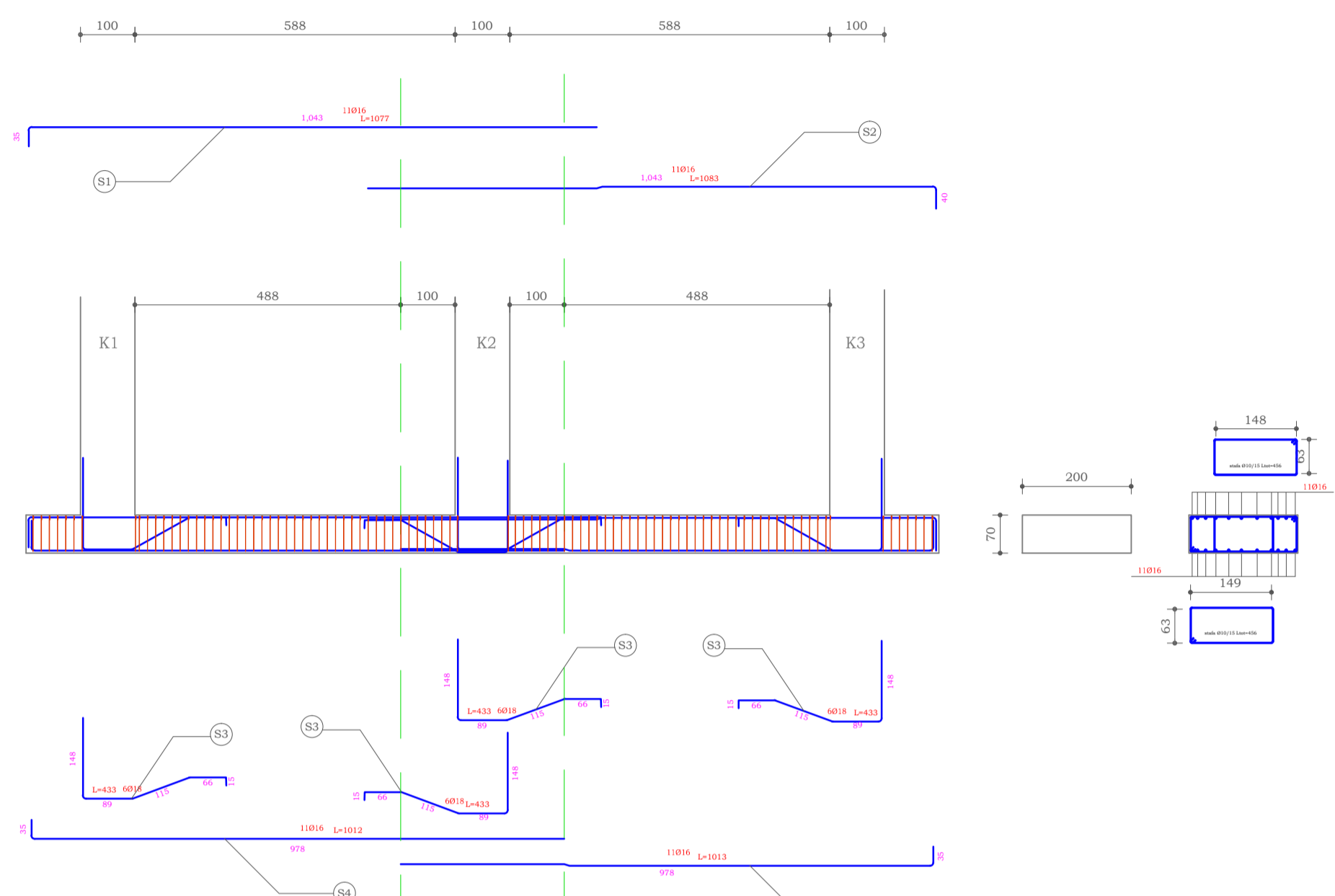

Shifra	Ø	COPE	Gjatësi (m)	Gjatësi tot (m)	Pesha (kg)
S1	Ø16	11	10.77	118.47	186.94
S2	Ø16	11	10.83	119.13	187.98
S3	Ø16	24	4.33	103.92	207.63
S4	Ø16	11	10.12	111.32	175.66
S5	Ø16	11	10.13	111.43	175.83
Stafa	Ø10	90	1.68	151.2	93.3
					1027
					24m ³

Celik c-S S-400
Beton M-300

Trari i themelit sipas aksit 6-6

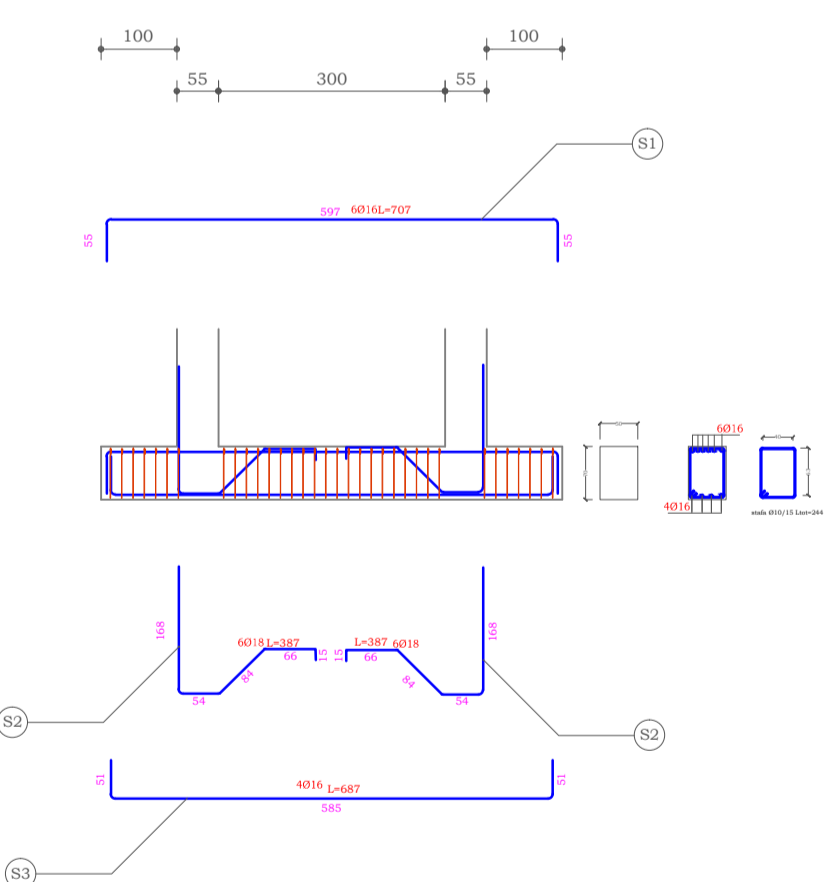

Shifra	Ø	COPE	Gjatësi (m)	Gjatësi tot (m)	Pesha (kg)
S1	Ø16	6	7.07	42.42	67
S2	Ø16	12	3.87	46.44	92.79
S3	Ø16	4	6.87	28	44
Stafa	Ø10	32	2.44	78	48
					282
					2.2 m ³

Celik c-S S-400
Beton M-300

TRARI I THEMELIT SIPAS AKSIT 2-2
TRARI I THEMELIT SIPAS AKSIT 3-3
TRARI I THEMELIT SIPAS AKSIT 4-4

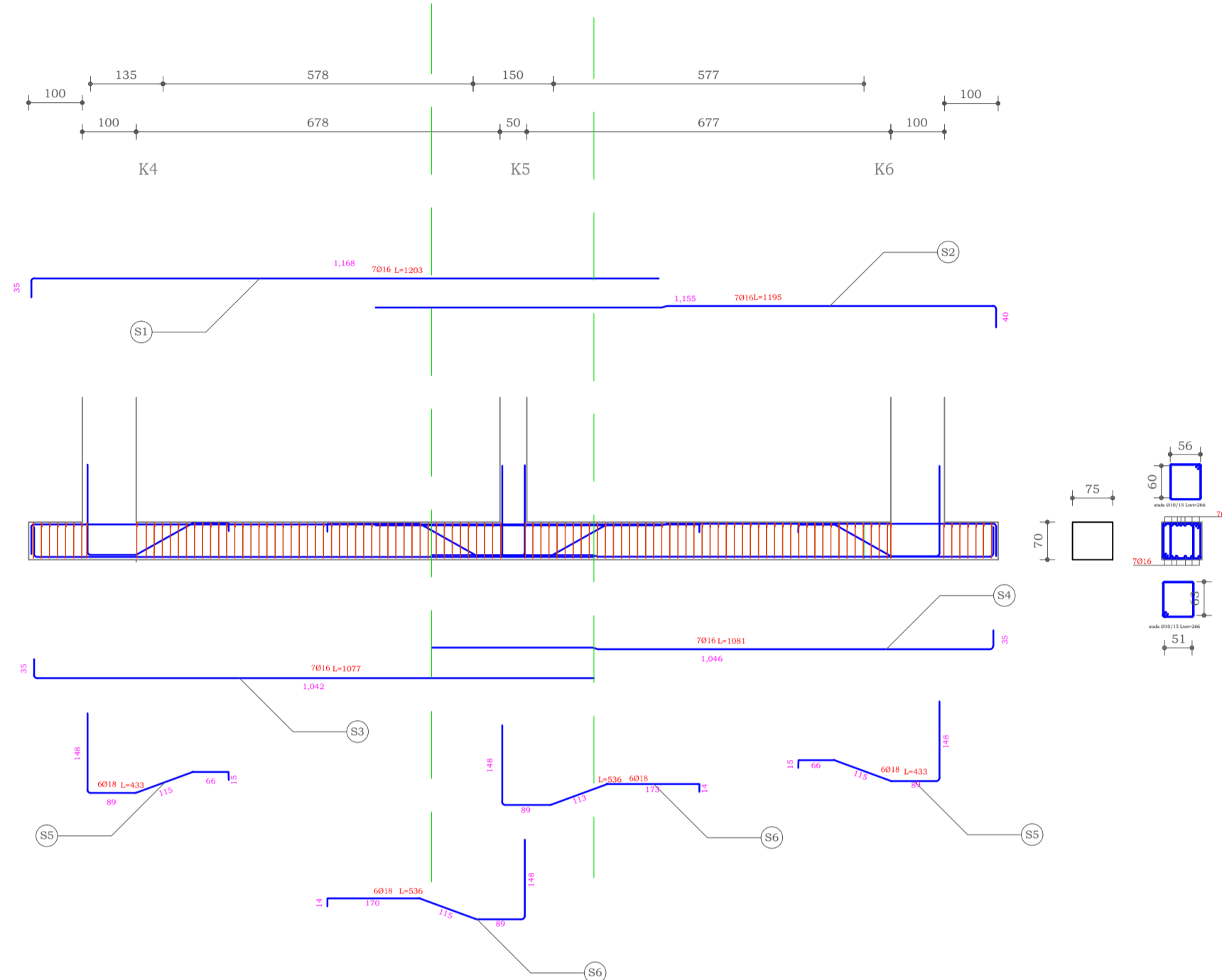

SHIFRA	Ø	COPE	GJATESIA (m)	GJATESIA TOT (m)	PESHA (kg)
S1	Ø16	7	12.03	84.2	132
S2	Ø16	7	11.95	83.65	131
S3	Ø18	12	4.23	51.96	103.81
S4	Ø16	7	10.77	75.39	119
S5	Ø16	7	10.81	75.67	118
S6	Ø16	22	5.29	116.38	183.65
Stafa	Ø10	102	4.52	461	281
					1569
					3205
					25.7m ³

Celik c-S S-400
Beton M-300

Trari i themelit sipas aksit E
Trari i themelit sipas aksit F

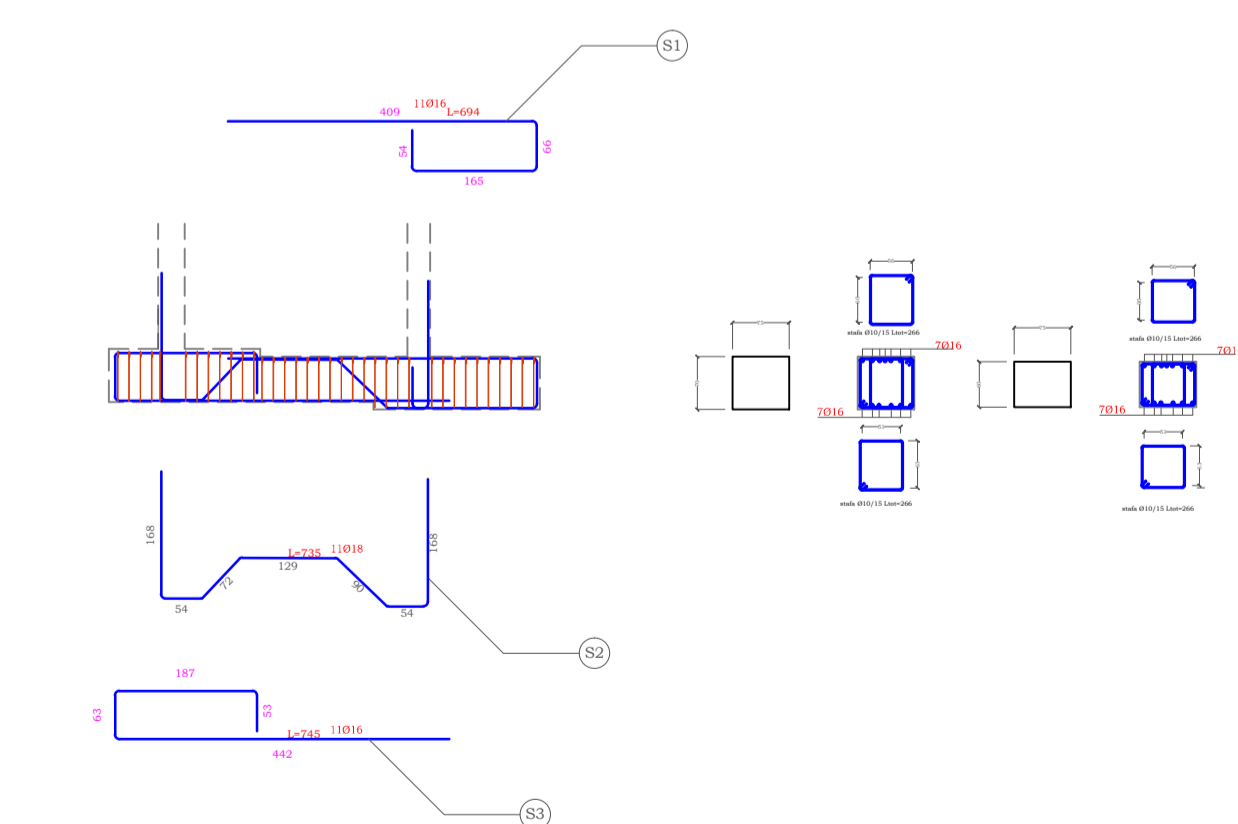

Shifra	Ø	COPE	Gjatësi(m)	Gjatësi tot(m)	Peshë(kg)
S1	Ø16	11	6.94	76.34	120.46
S2	Ø18	6	7.35	44.1	88.11
S3	Ø16	11	7.45	81.65	129.32
Stafa	Ø10	32	1.68	53.76	33.17
					377
					742
					6m ³

Celik c-S S-400
Beton M-300

Prerje :

Sipas aksit 2-2

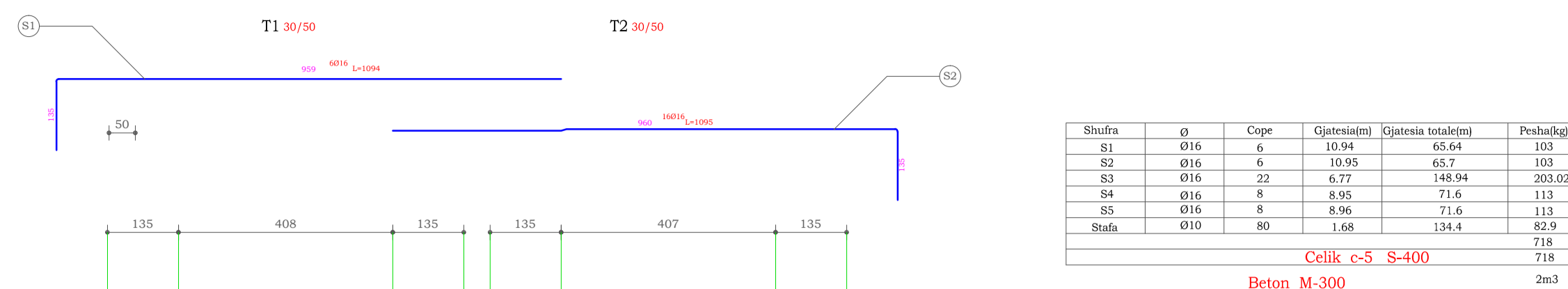

Shifra	Ø	COPE	Gjatesia(m)	Gjatesia tot(m)	Peshë(kg)
S1	Ø16	6	10.94	65.64	103
S2	Ø16	4	10.94	65.7	108
S3	Ø16	22	4.77	149.94	203.02
S4	Ø16	8	8.95	71.6	113
S5	Ø16	8	8.96	71.6	113
Stafa	Ø10	80	1.68	134.4	82.9
					718
					718
					2m ³

Celik c-S S-400
Beton M-300

Sipas aksit 3-3

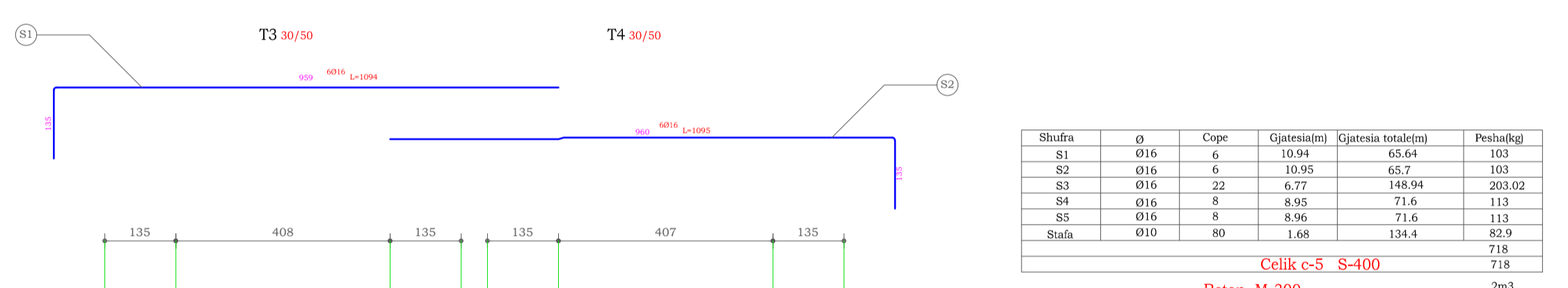

Shifra	Ø	COPE	Gjatesia(m)	Gjatesia tot(m)	Peshë(kg)
S1	Ø16	6	10.94	65.64	103
S2	Ø16	4	10.94	65.7	108
S3	Ø16	22	4.77	149.94	203.02
S4	Ø16	8	8.95	71.6	113
S5	Ø16	8	8.96	71.6	113
Stafa	Ø10	80	1.68	134.4	82.9
					718
					718
					2m ³

Celik c-S S-400
Beton M-300

Sipas aksit 4-4

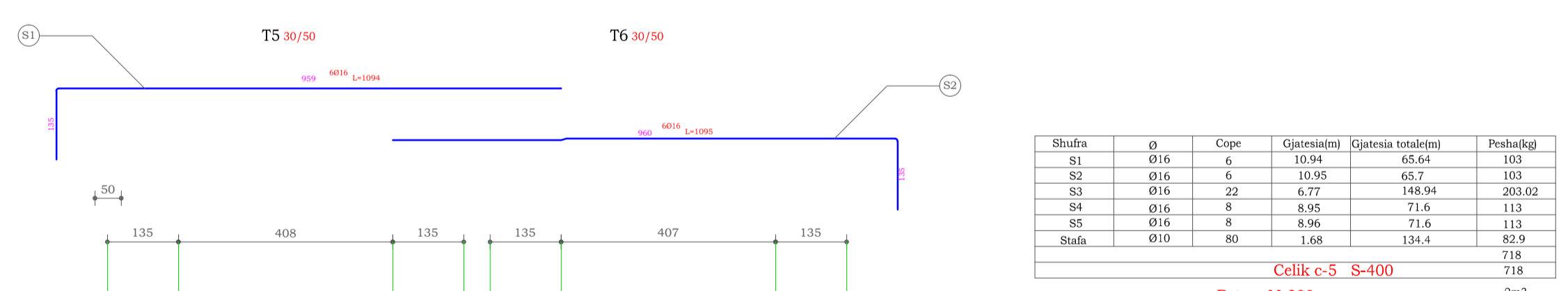

Shifra	Ø	COPE	Gjatesia(m)	Gjatesia tot(m)	Peshë(kg)
S1	Ø16	6	10.94	65.64	103
S2	Ø16	4	10.94	65.7	108
S3	Ø16	22	4.77	149.94	203.02
S4	Ø16	8	8.95	71.6	113
S5	Ø16	8	8.96	71.6	113
Stafa	Ø10	80	1.68	134.4	82.9
					718
					718
					2m ³

Celik c-S S-400
Beton M-300

Sipas aksit E-E

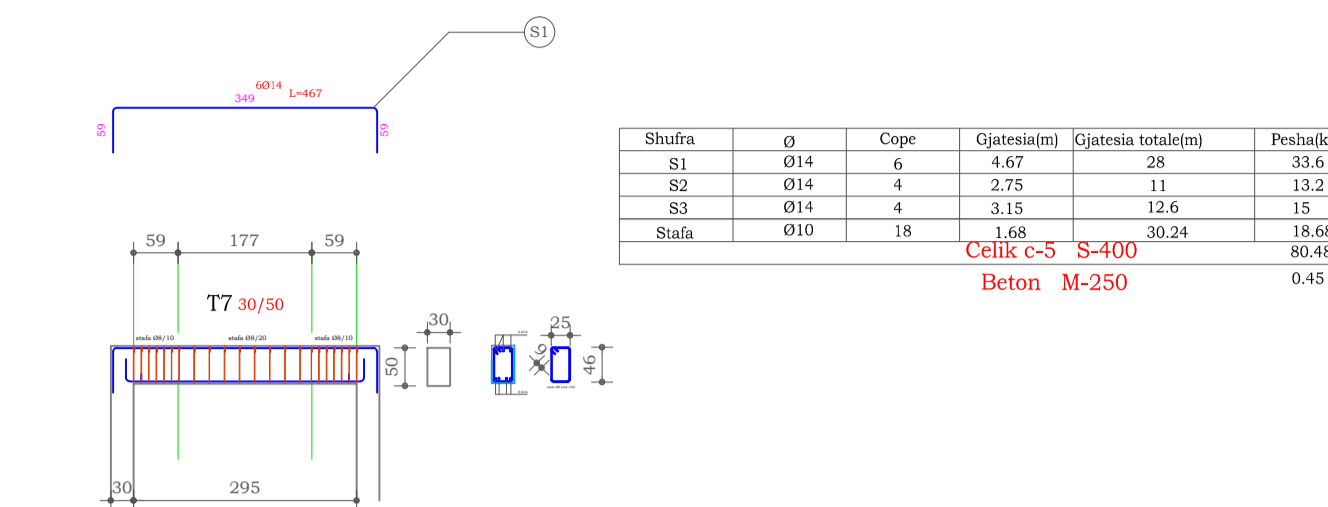

Shifra	Ø	COPE	Gjatesia(m)	Gjatesia tot(m)	Peshë(kg)
S1	Ø14	2	4.07	28	33.6
S2	Ø14	4	3.75	11	13.2
S3	Ø14	4	3.15	12.6	15
Stafa	Ø10	18	1.68	30.24	18.68
					80.48
					0.45 m ³

Celik c-S S-400
Beton M-250

T1 30/50	Beton Vc1.015m ³
T2 30/50	Beton Vc1.015m ³
T3 30/50	Beton Vc1.015m ³
T4 30/50	Beton Vc1.015m ³
T5 30/50	Beton Vc1.015m ³
T6 30/50	Beton Vc1.015m ³
T7 30/50	Beton Vc0.4425m ³
T8 30/50	Beton Vc0.45m ³
T9 30/50	Beton Vc0.4425m ³
Total	Beton Vc7.63 m ³

Sipas aksit 6-6

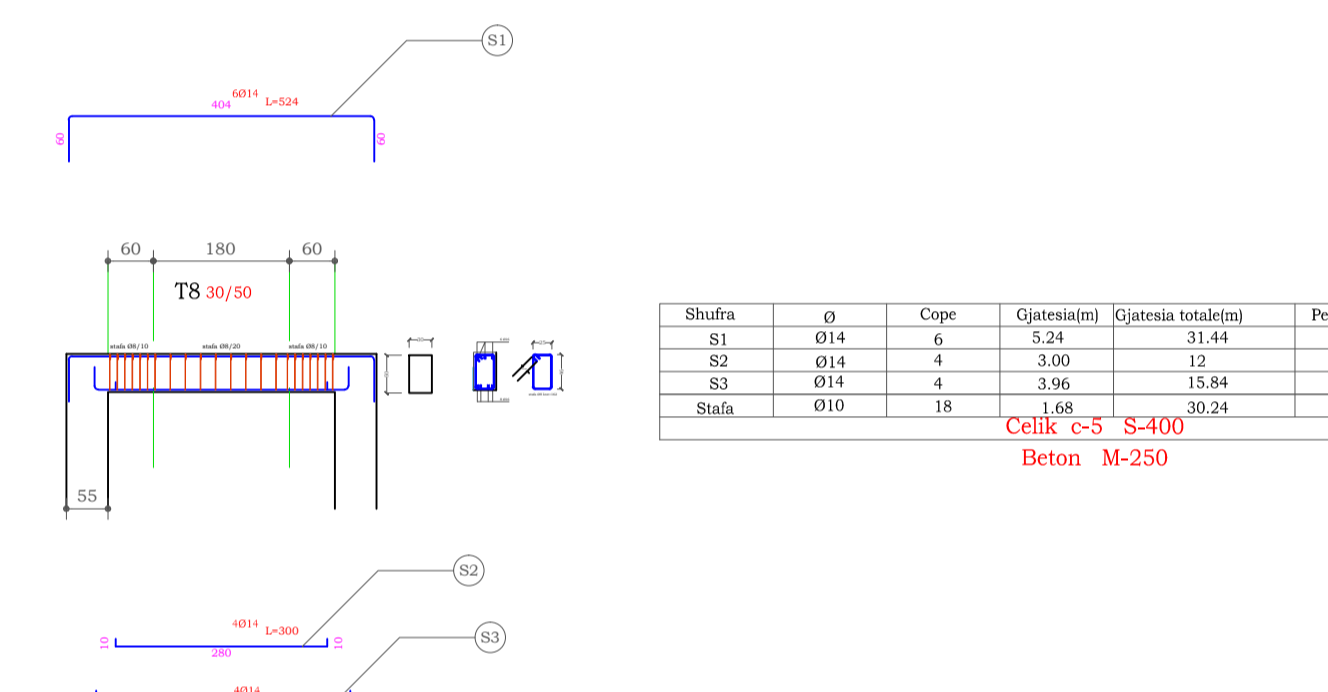

Shifra	Ø	COPE	Gjatesia(m)	Gjatesia tot(m)	Peshë(kg)
S1	Ø14	6	6.24	31.44	38
S2	Ø14	6	3.90	12	14.4
S3	Ø14	4	3.96	15.84	19
Stafa	Ø10	28	1.68	30.24	18.68
					90
					0.45 m ³

Celik c-S S-400
Beton M-250

Sipas aksit F-F

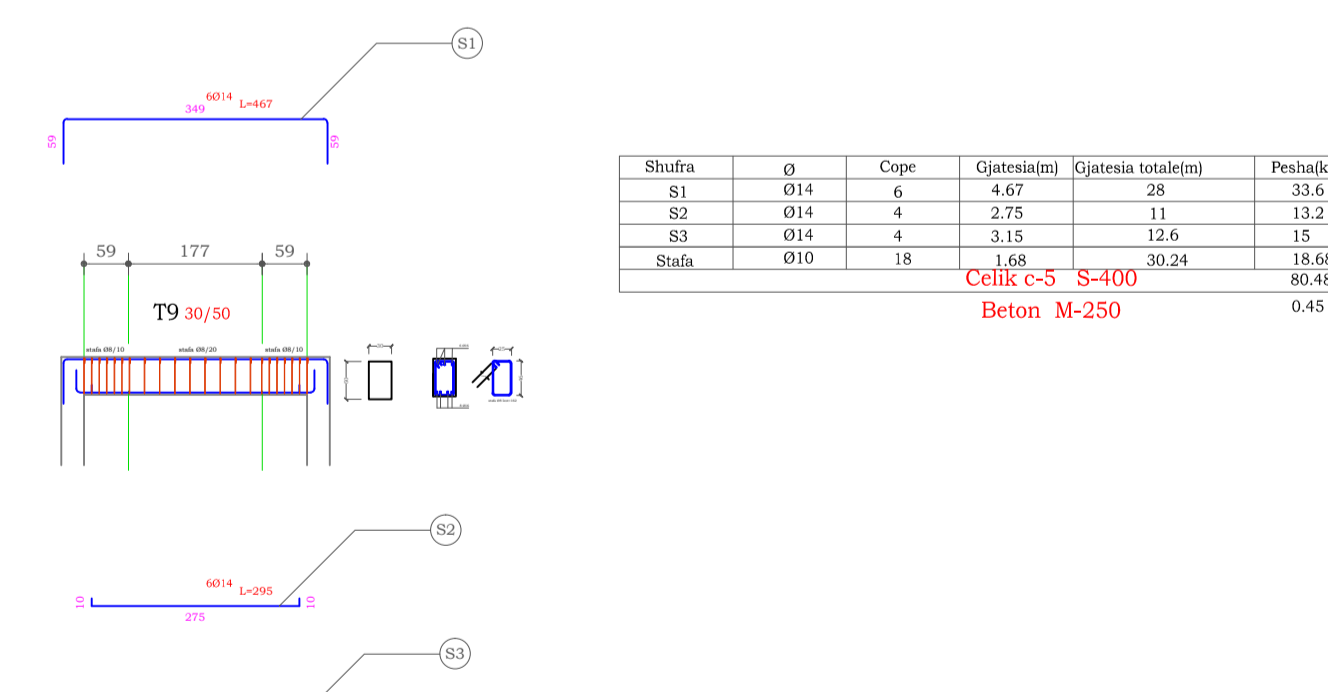

Shifra	Ø	COPE	Gjatesia(m)	Gjatesia tot(m)	Peshë(kg)
S1	Ø14	6	4.07	28	33.6
S2	Ø14	4	3.75	11	13.2
S3	Ø14	4	3.15	12.6	15
Stafa	Ø10	18	1.68	30.24	18.68
					80.48
					0.45 m ³

Celik c-S S-400
Beton M-250

"SPHAERA" sh.p.k
PROJEKTIM SUPERVIZION KOLAUDIM
Rruga "QAZIM VATHI" nr 106 Tirane
Mobile: 00355 69 20 38848
e-mail: ajkidtopore@sphaera.al
ajkidtopore@yahoo.com
website: www.sphaera.al

REPUBLIKA E SHQIPERISE
Ministria e Puneve Publike Transportit dhe Telekomunikacionit
DREJTORIA E PERGJITHSHME
E UJESJELLESIT DHE KANANIZIMEVE

RIKONSTRUKSION I RRJETIT TE UJESJELLESIT RAJONAL
TE ZONES SE DUMRESE
RRETHI ELBASAN

Titulli i vizatimit:
01. DEPO (SHPERNDARES) GASTARE
ARMIMI I DEPOS fleta 3

"SPHAERA" sh.p.k | Pruga "QAZIM VATHI" nr 106 Tirane
 PROJEKTIM SUPERVIZION KOLAUDIM
 Mobile: 00355 69 20 38848
 e-mail: ajkidtopore@sphaera.al
 ajkidtopore@yahoo.com
 website: www.sphaera.al

REPUBLIKA E SHQIPERISE
 Ministria e Puneve Publike Transportit dhe Telekomunikacionit
 DREJTORIA E PERGJITHSHEME
 E UJESJELLESIT DHE KANANIZIMEVE

RIKONSTRUKSION I RRJETIT TE UJESJELLESIT RAJONAL
 TE ZONES SE DUMRESE
 RRETHI ELBASAN

Titulli i vizatimit:
**01. DEPO (SHPERNDARES) GASTARE
 ARMIMI I DEPOS *fleta 4***

FALA/PROJEKTI	PROJEKT ZBATIMI	DATA	PRELL 2013	Ing. Ajkid Topore
NUMRI I VIZATIMIT	PL_D-01E	NR. FALA	1:100	Punoi Ing. Hysni Ruka Ing. Anil Xhielepi Përpunoi Ing. Edo Kamberaj

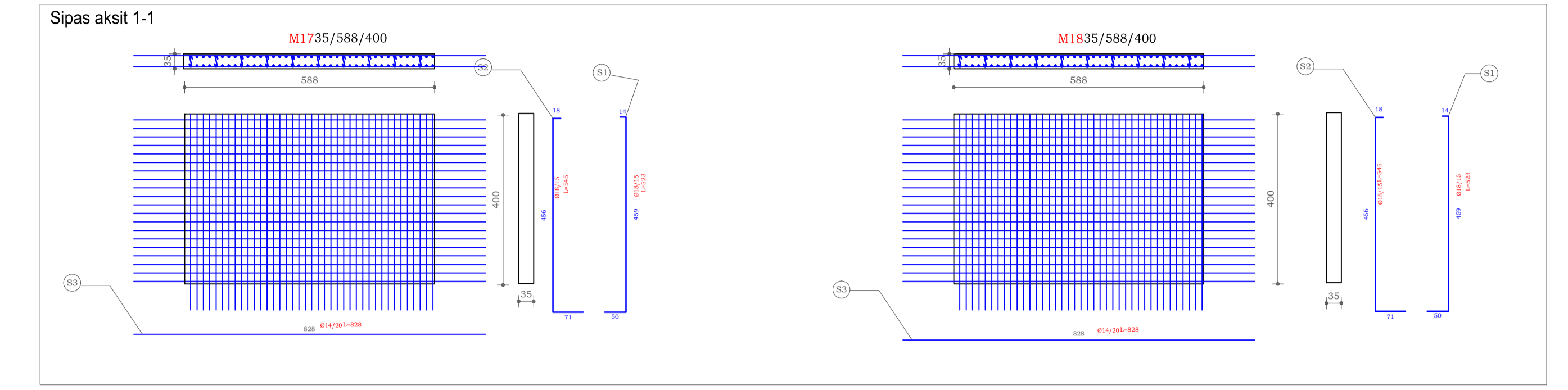

M18 35/588/400
M17 35/588/400

Shifra	Ø	Copë	Gjatësia	Gjatësia net (m)	Pesha (kg)
S1	Ø18	39	5.33	200.70	407.61
S2	Ø18	39	5.45	212.76	434.47
S3	Ø14	40	6.20	312.2	397.41

Celik c-S S-400

M14 35/435/400

Shifra	Ø	Copë	Gjatësia	Gjatësia net (m)	Pesha (kg)
S1	Ø18	9	5.33	41.67	84.00
S2	Ø18	9	5.45	43.05	86.3
S3	Ø14	40	3.88	153.2	186.24

Celik c-S S-400

M15 35/435/400

Shifra	Ø	Copë	Gjatësia	Gjatësia net (m)	Pesha (kg)
S1	Ø18	10	5.33	43.05	86.3
S2	Ø18	10	5.45	44.5	89.21
S3	Ø14	40	3.93	157.2	186.24

Celik c-S S-400

M7 50/435/400 **M13 35/435/400**
M6 50/435/400 **M12 35/435/400**
M4 35/435/400 **M11 35/435/400**
M3 35/435/400 **M9 35/435/400**
M2 35/435/400 **M8 50/435/400**
M1 35/435/400

Shifra	Ø	Copë	Gjatësia	Gjatësia net (m)	Pesha (kg)
S1	Ø18	26	5.33	164.44	329.58
S2	Ø18	26	5.45	167.9	336.9
S3	Ø14	40	6.75	270.0	324.0

Celik c-S S-400

M16 35/435/400

Shifra	Ø	Copë	Gjatësia	Gjatësia net (m)	Pesha (kg)
S1	Ø18	26	5.33	160.05	323.3
S2	Ø18	26	5.45	163.75	329.21
S3	Ø14	40	7.75	310	372

Celik c-S S-400

BETON

Shifra	Ø	Copë	Gjatësia	Gjatësia net (m)	Pesha (kg)
M1	35/435/400	6.09m ³			
M2	35/435/400	6.09m ³			
M3	35/435/400	6.09m ³			
M4	35/435/400	6.09m ³			
M5	50/435/400	6.09m ³			
M6	50/435/400	6.09m ³			
M7	50/435/400	6.09m ³			
M8	50/435/400	6.09m ³			
M9	35/435/400	6.09m ³			
M10	35/435/400	6.09m ³			
M11	35/435/400	6.09m ³			
M12	35/435/400	6.09m ³			
M13	35/435/400	6.09m ³			
M14	35/435/400	6.09m ³			
M15	35/435/400	6.09m ³			
M16	35/435/400	6.09m ³			
M17	35/435/400	6.09m ³			
M18	35/435/400	6.09m ³			

110 m³

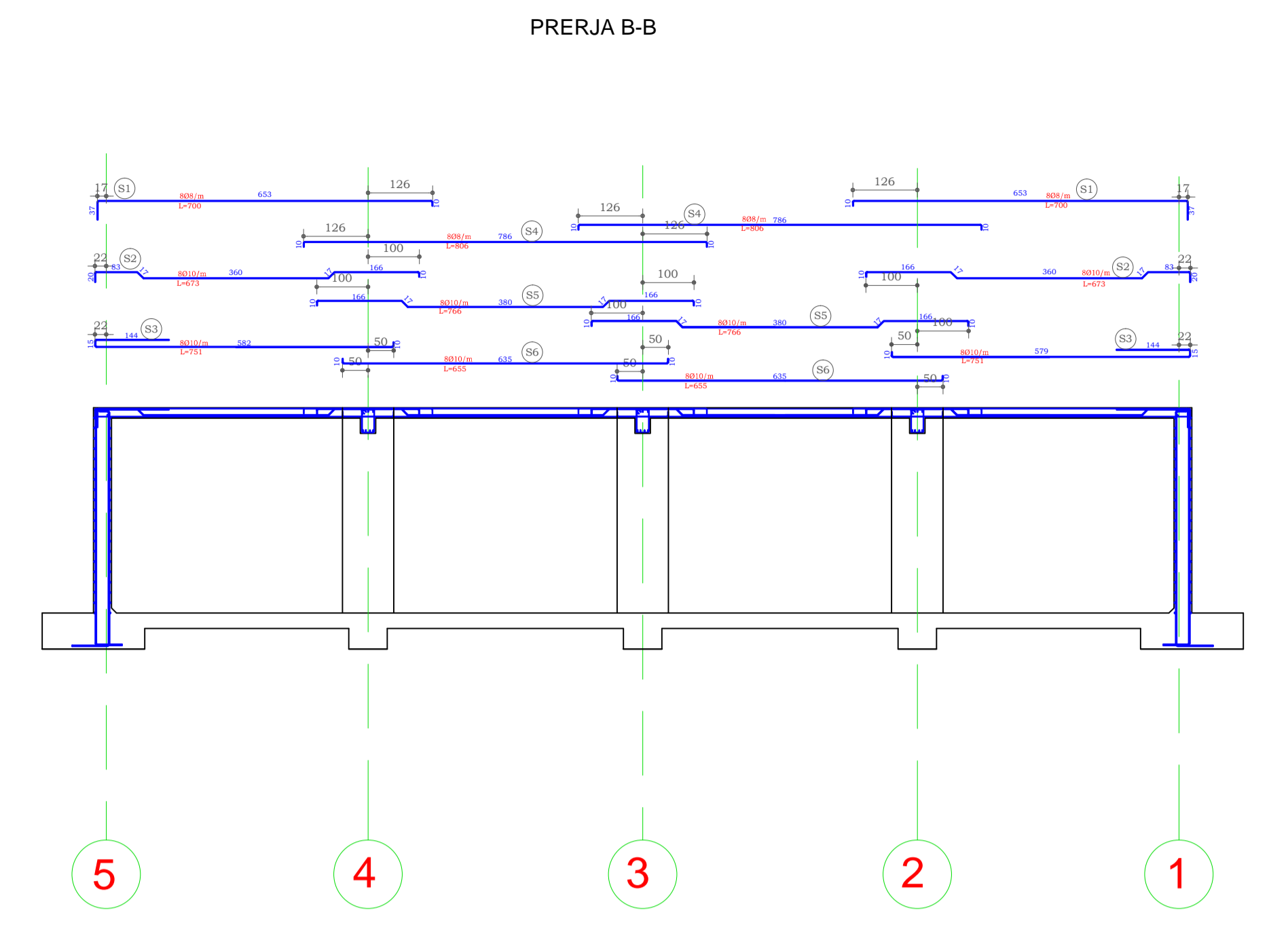
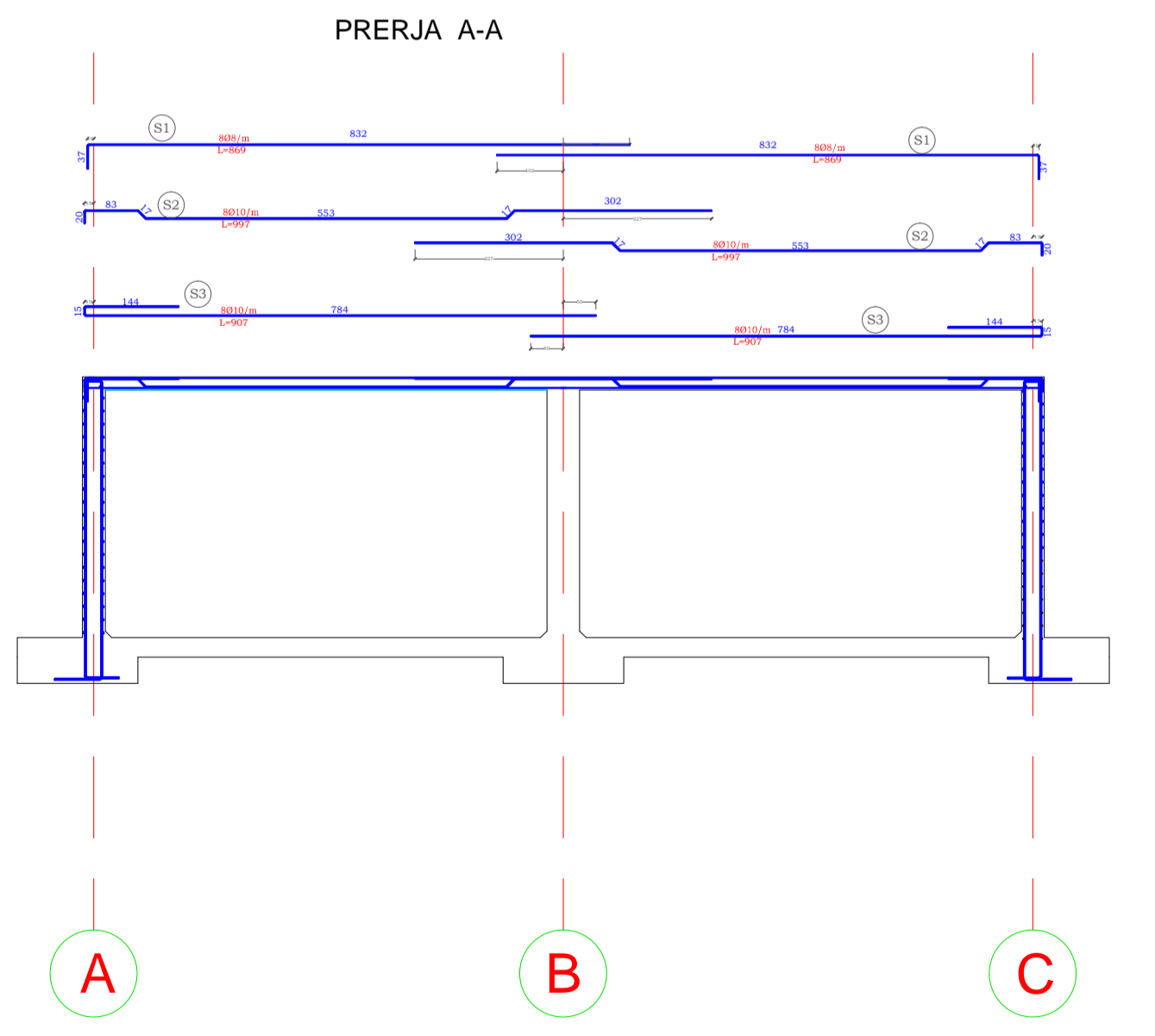
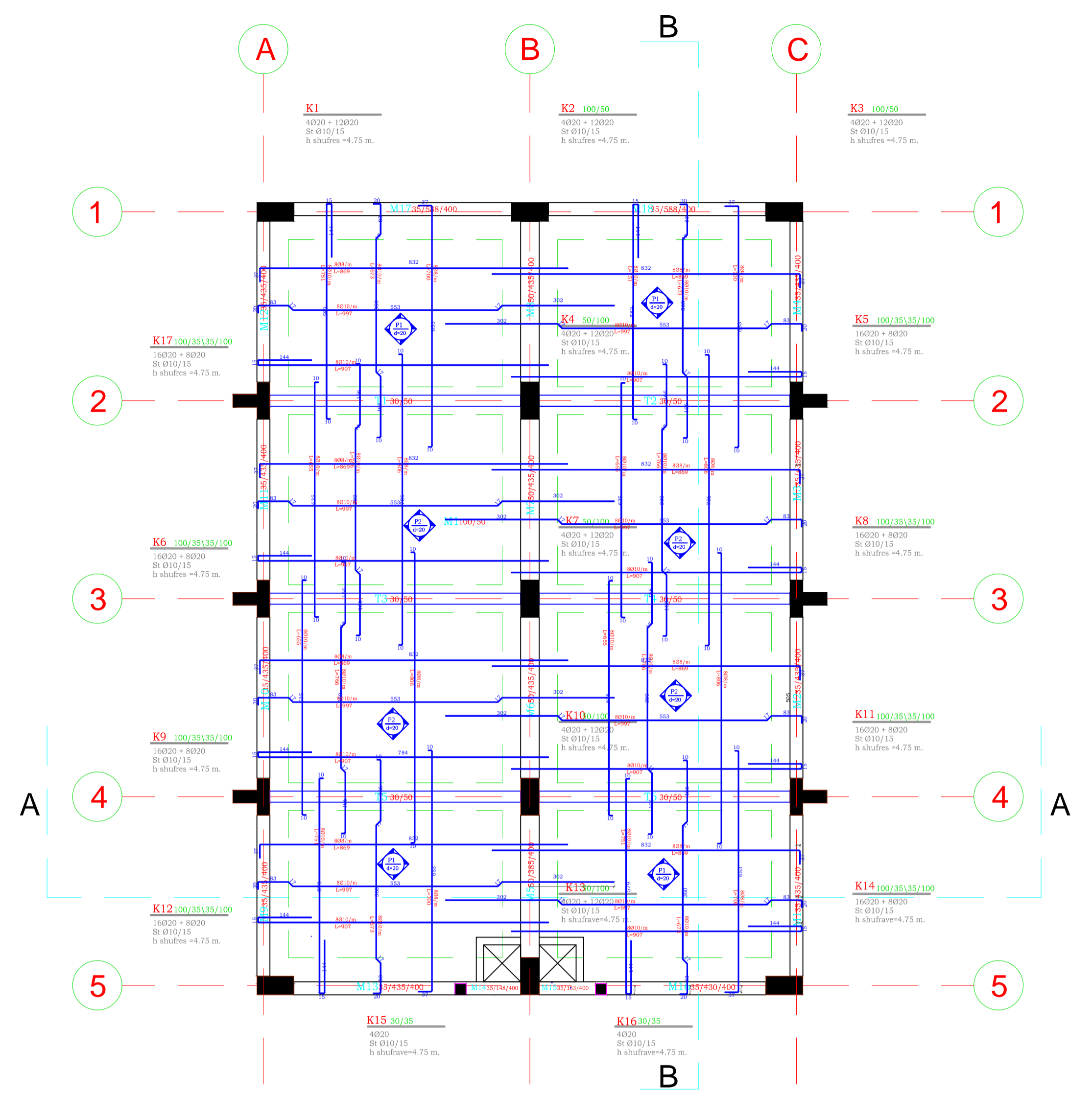
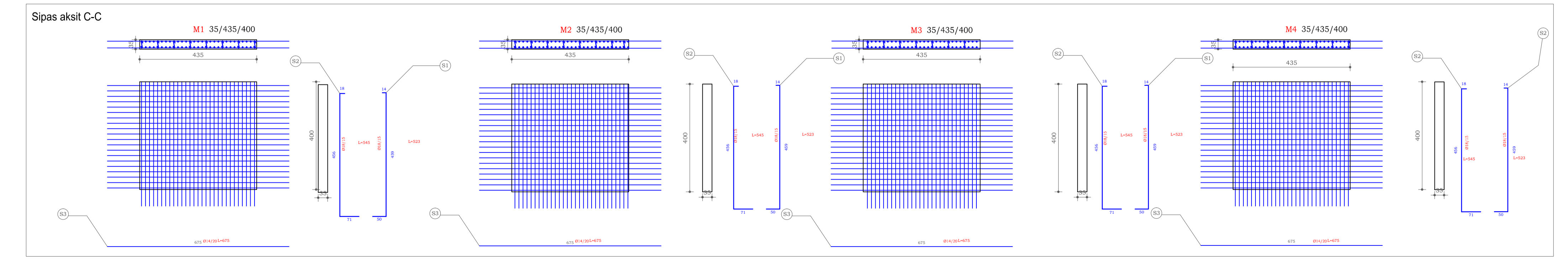
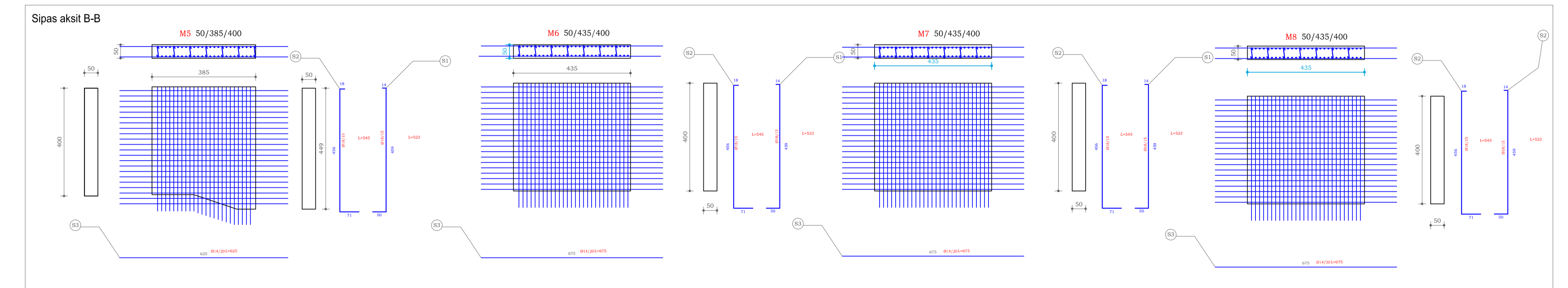
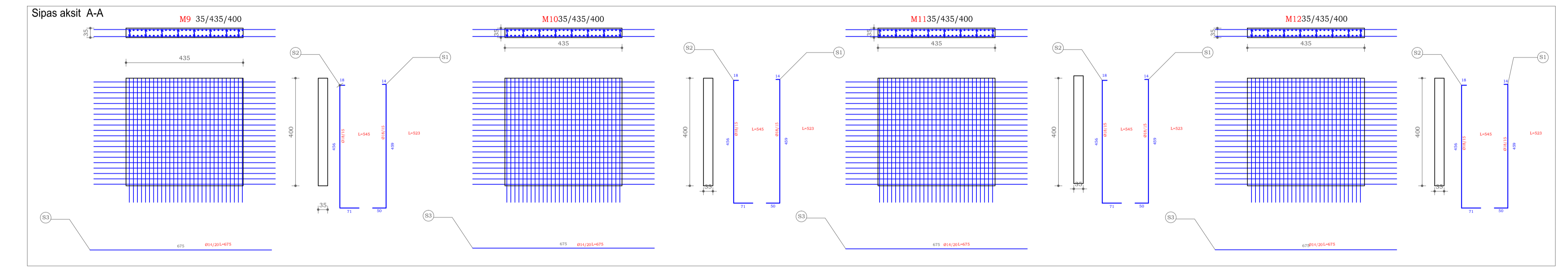
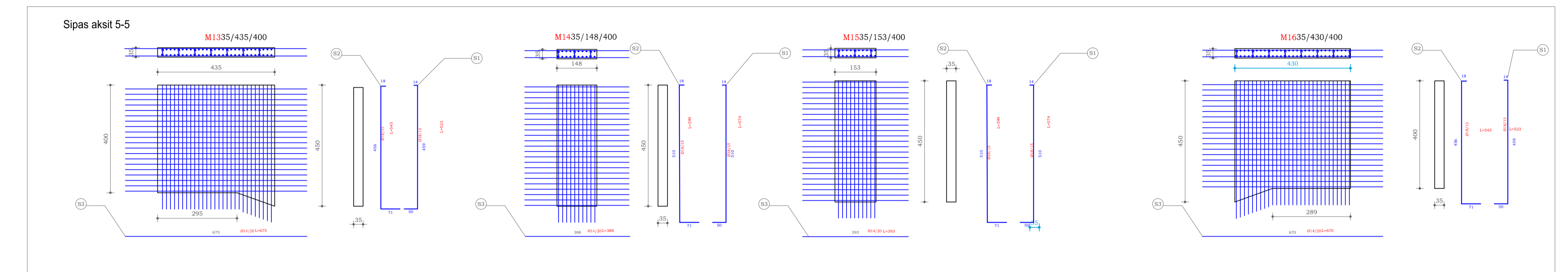

Concrete 67m³

total sipas A-A

Shifra	Ø	Copë	Gjatësia	Gjatësia net (m)	Pesha (kg)
S1	Ø18	320	4.69	1500	3000
S2	Ø18	320	4.69	1500	3000
S3	Ø14	320	9.37	3000	6000

Celik c-S S-400

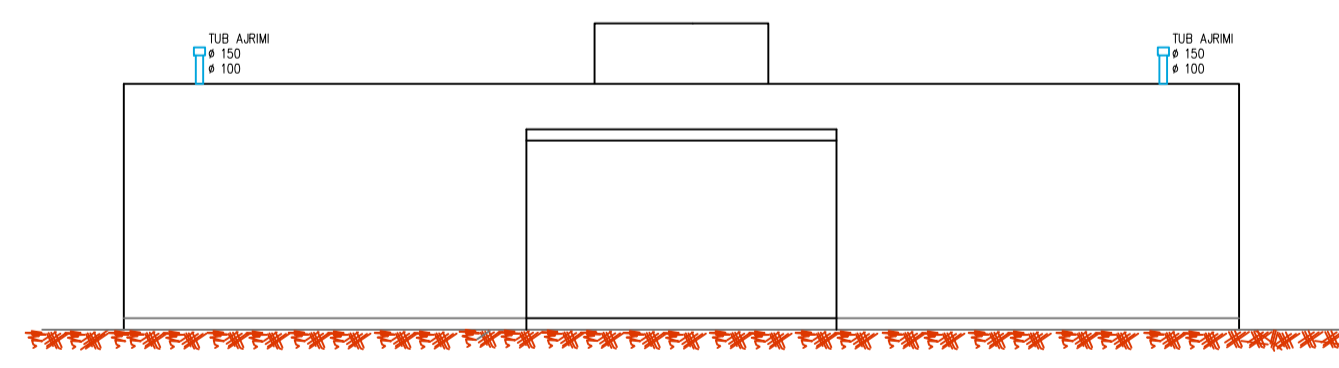
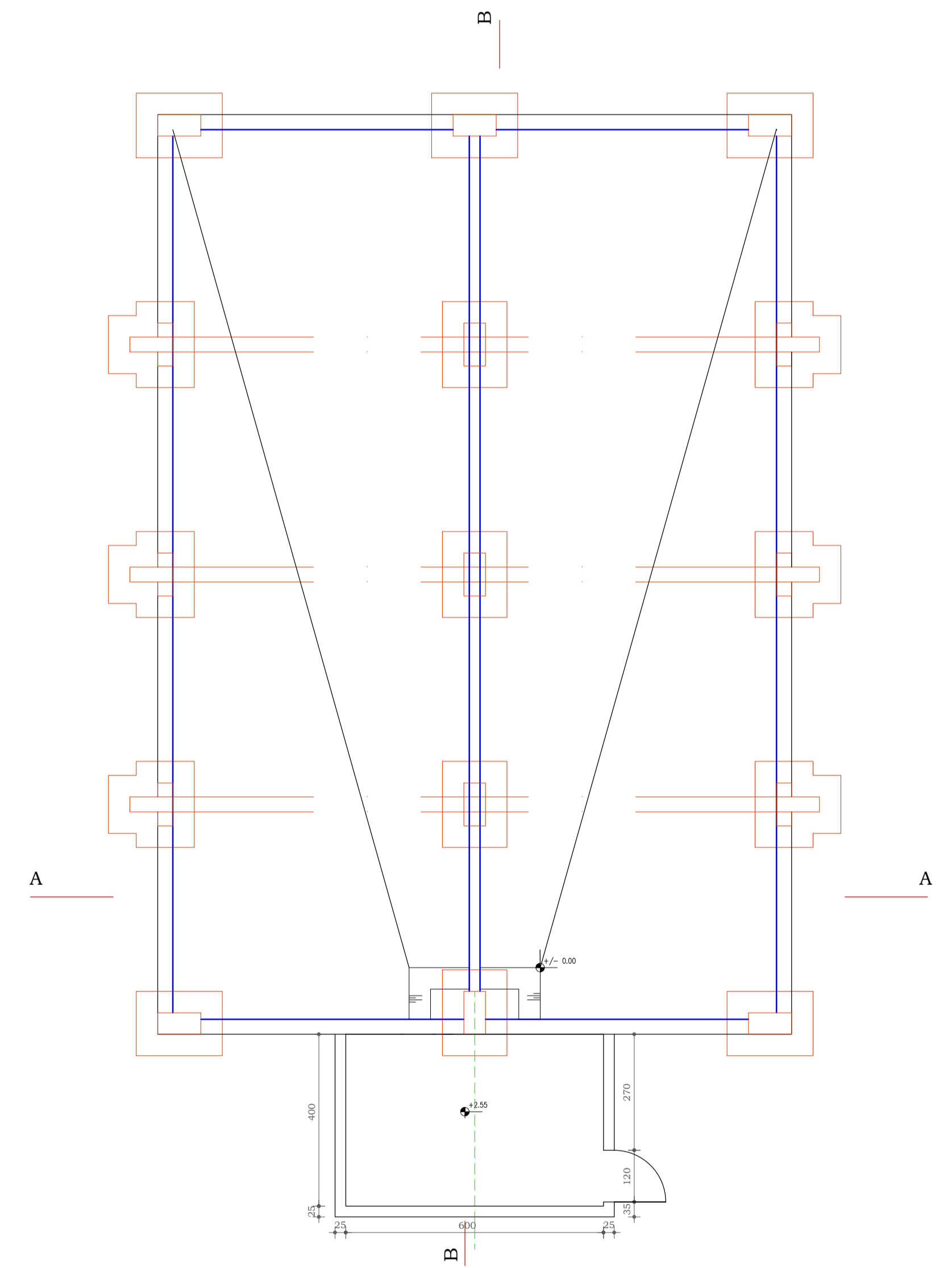
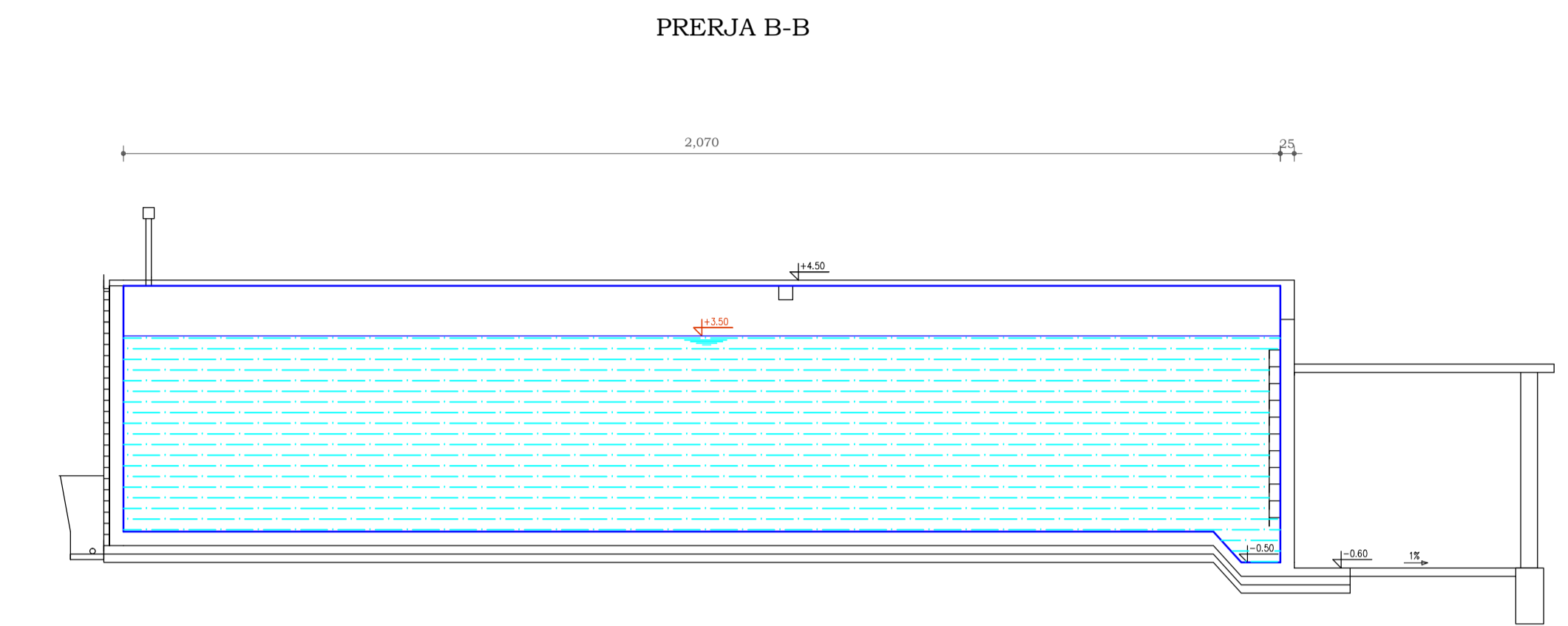
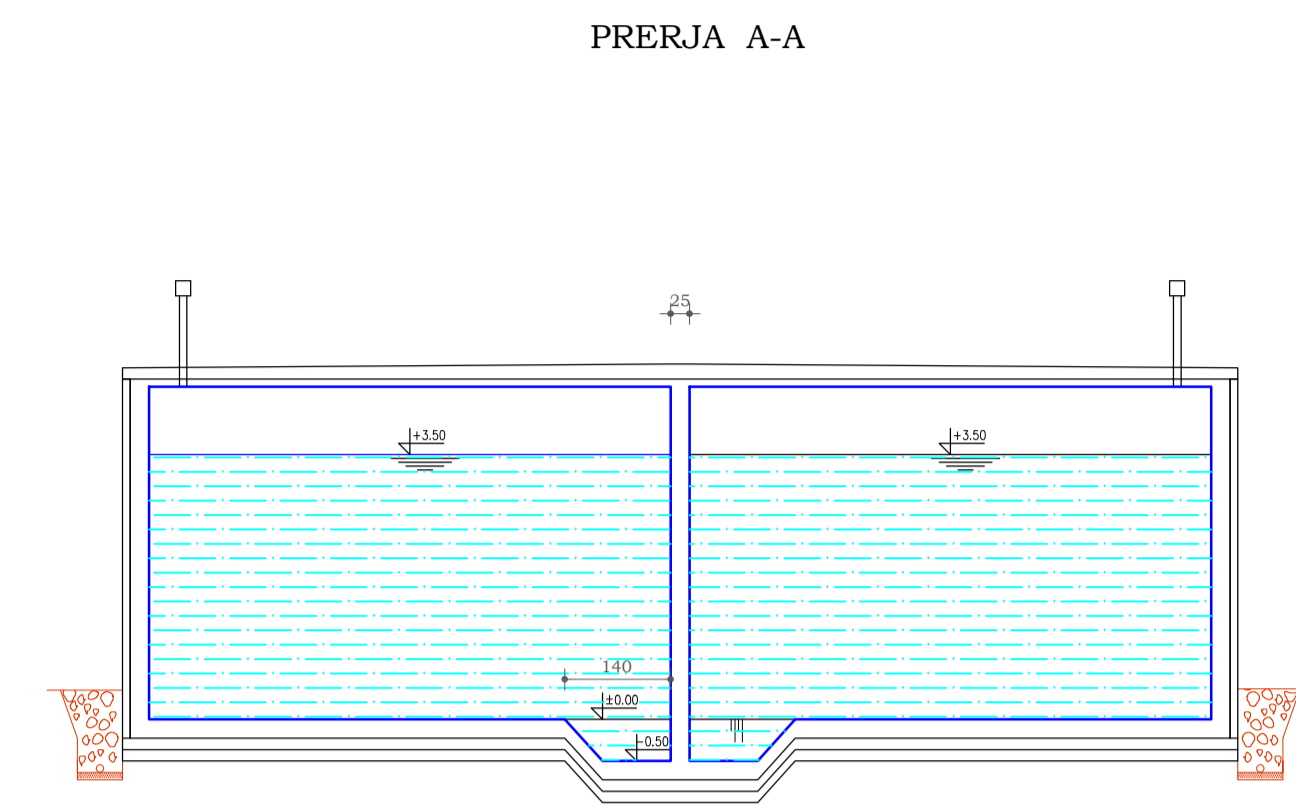
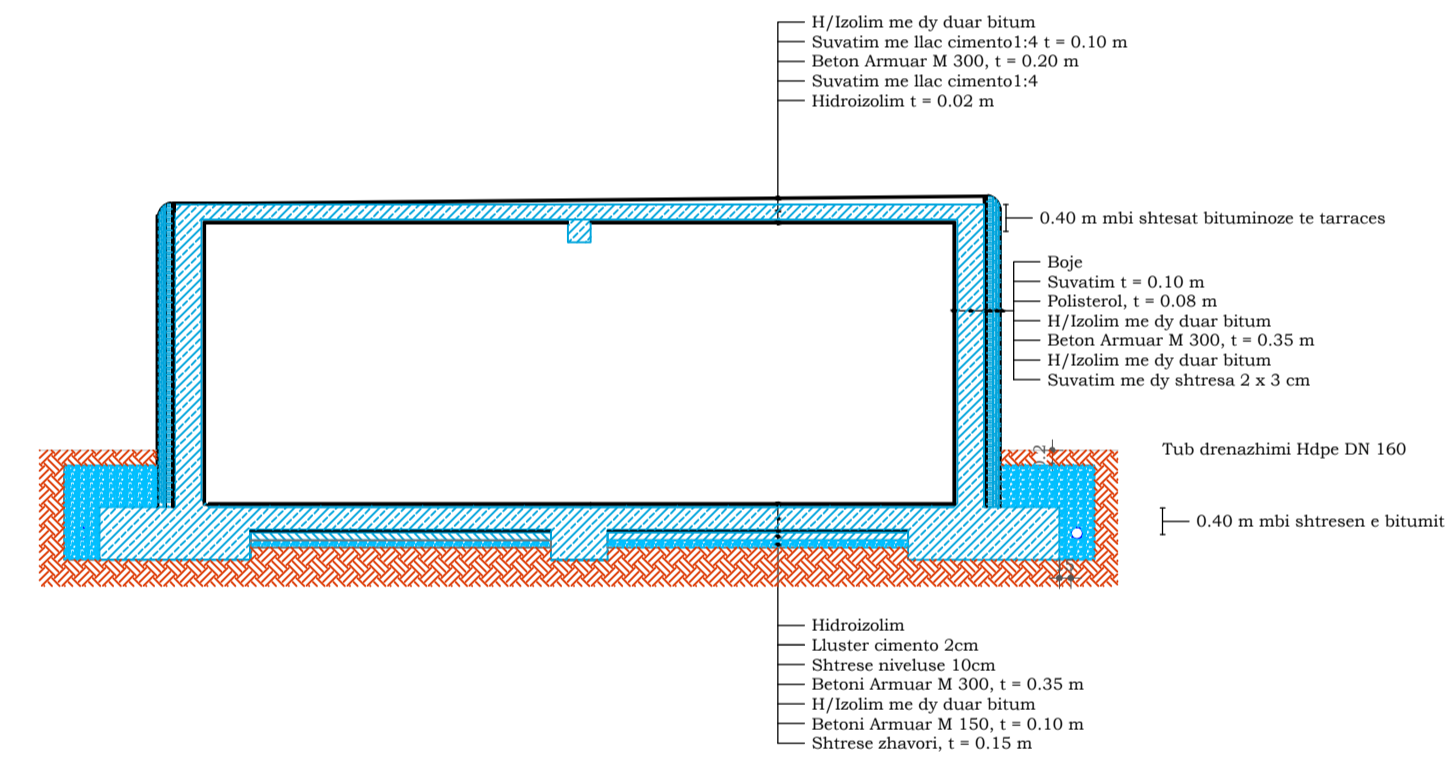
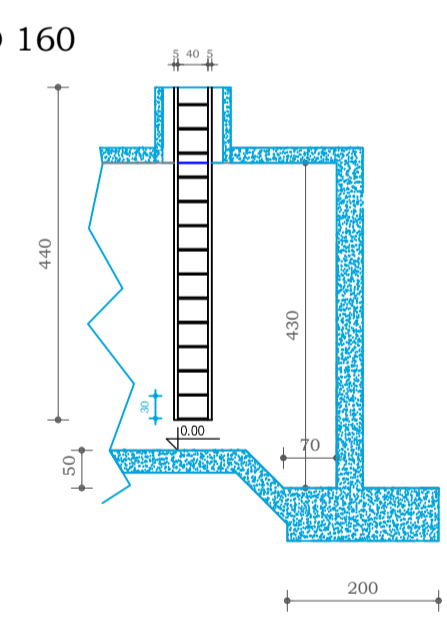
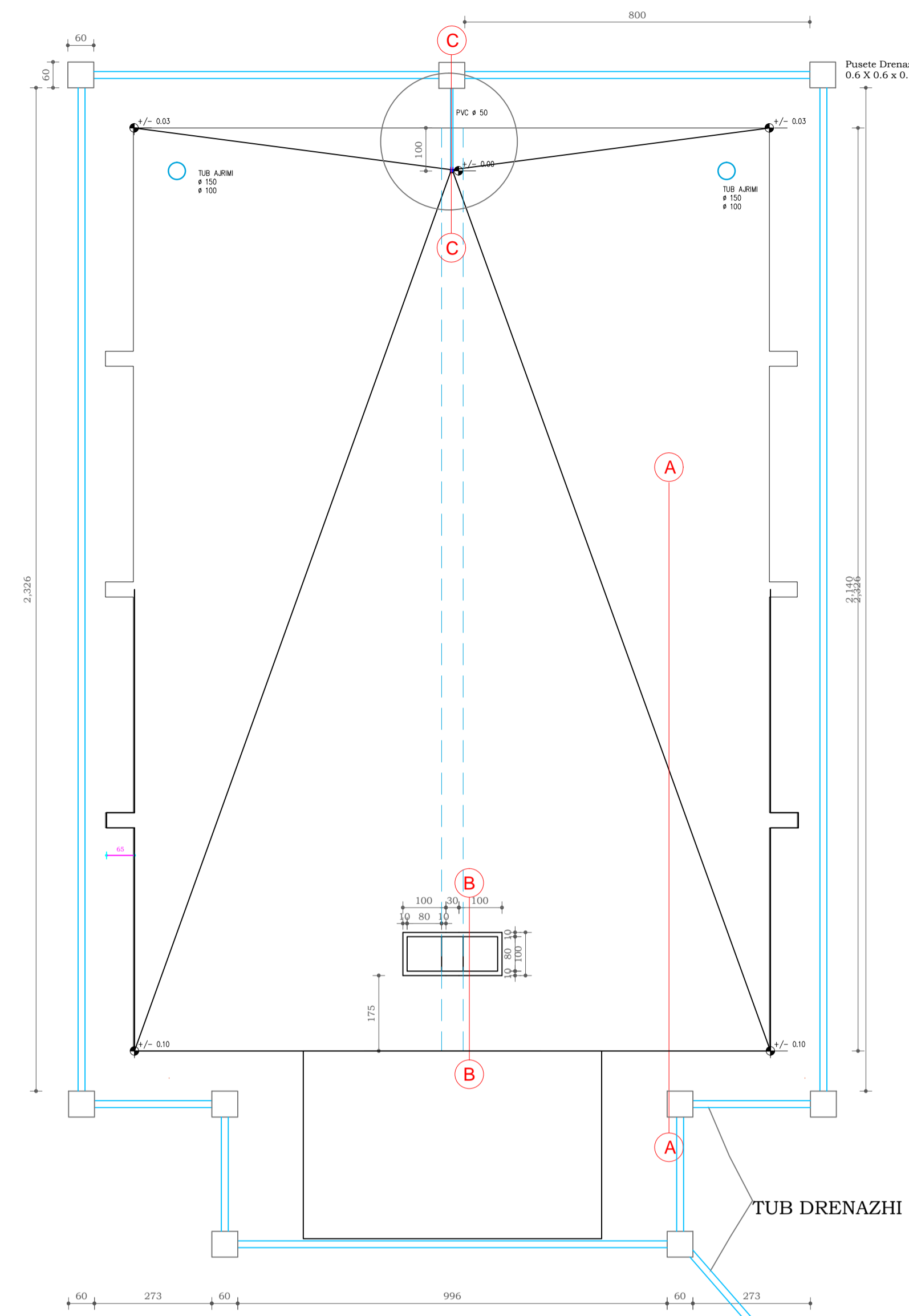

"SPHAERA" sh.p.k
 PROJEKTIM
 SUPERVIZION
 KOLAUDIM

Mobile: 00355 69 20 38848
 e-mail: ajkidtopore@sphaera.al
ajkidtopore@yahoo.com
 website: www.sphaera.al

REPUBLIKA E SHQIPERISE
 Ministria e Puneve Publike Transportit dhe Telekomunikacionit
 DREJTORIA E PERGJITHSHME
 E UJESJELLESIT DHE KANANIZIMEVE

RIKONSTRUKSION I RRJETIT TE UJESJELLESIT RAJONAL
 TE ZONES SE DUMRESE
 RRETHI ELBASAN

Titulli i vizatimit:
 01. DEPO (SHPERNDARES) GASTARE
 ARMIMI I DEPOS fleta 5

FAZA/PROJEKTI	PROJEKT ZBATIMI	DATA	PRILL 2013	Ing. Ajkid Topore
NUMRI I VIZATIMIT	PL_D-01F	SHKALLA	1:100	Punoi Ing. Hysni Ruka Ing. Anad Xhielepi Përpunoi Ing. Edo Kamberaj

PLANI I AKSEVE DHE KOLLONAVE
TE DHOMES SE MANOVRMIT DEPO BELSH

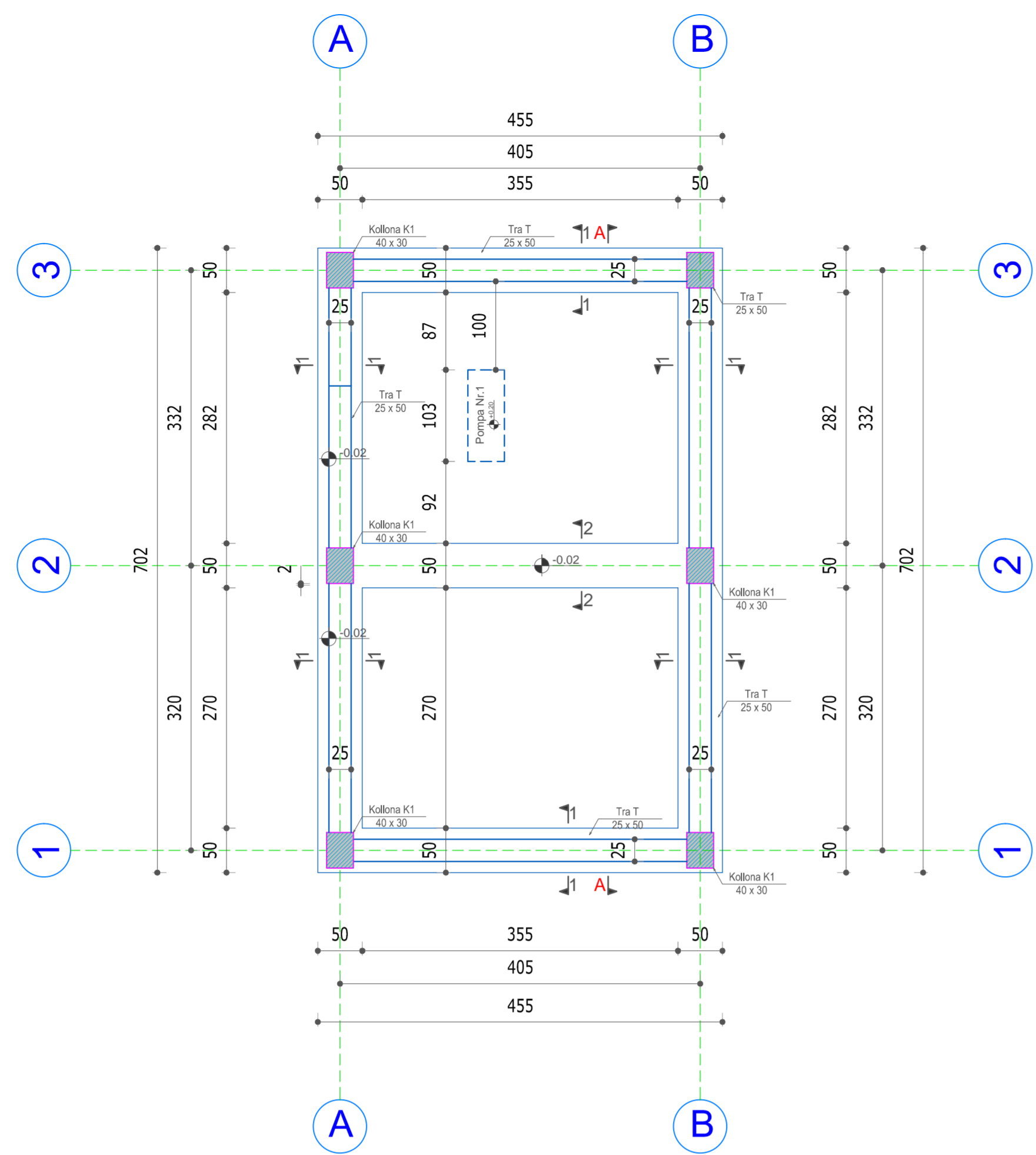

PLANI I STRUKTURAVE
TE DHOMES SE MANOVRMIT DEPO BELSH

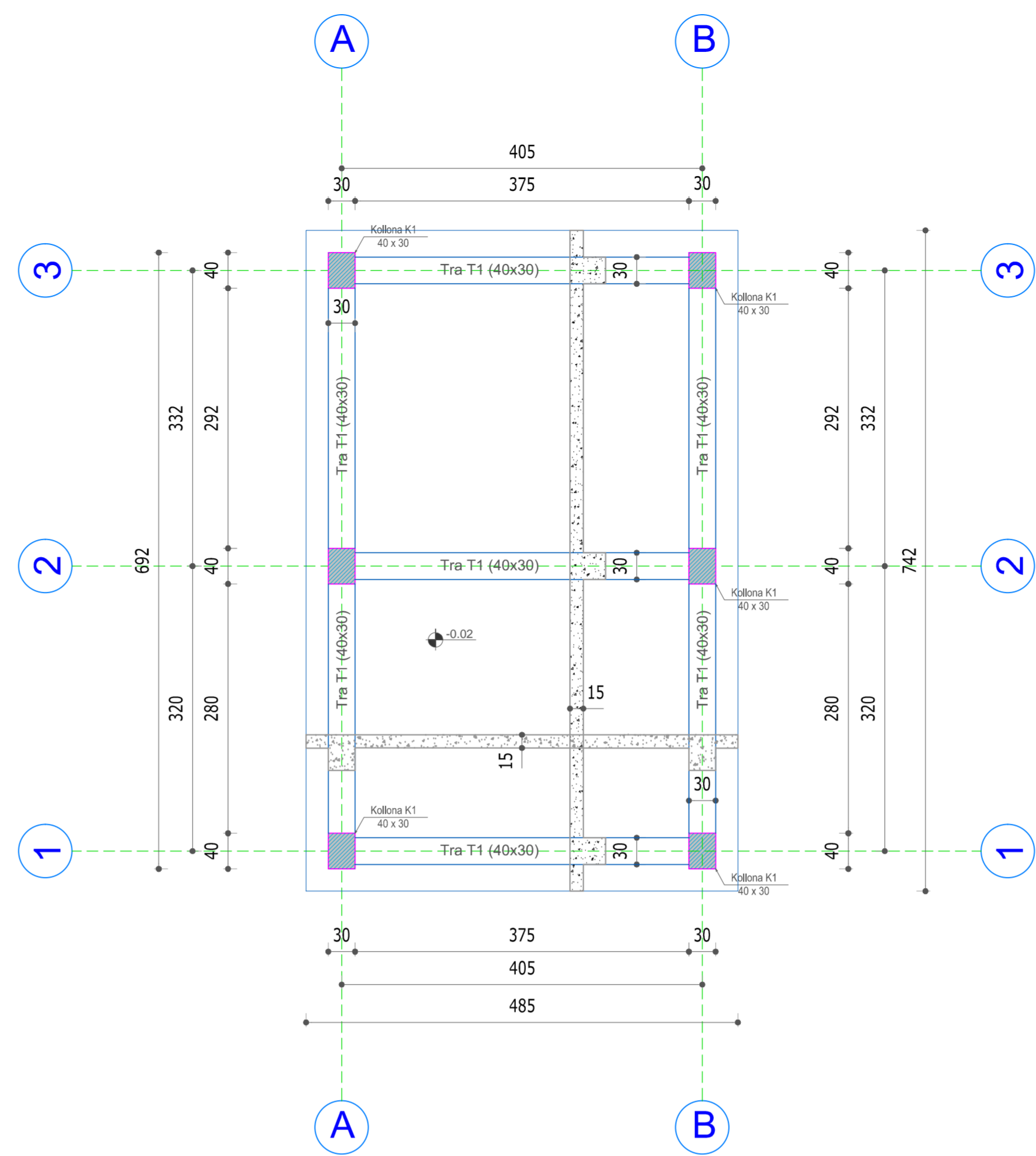

PLANI I STRUKTURAVE TE DHOMES SE MANOVRMIT
DEPO BELSH

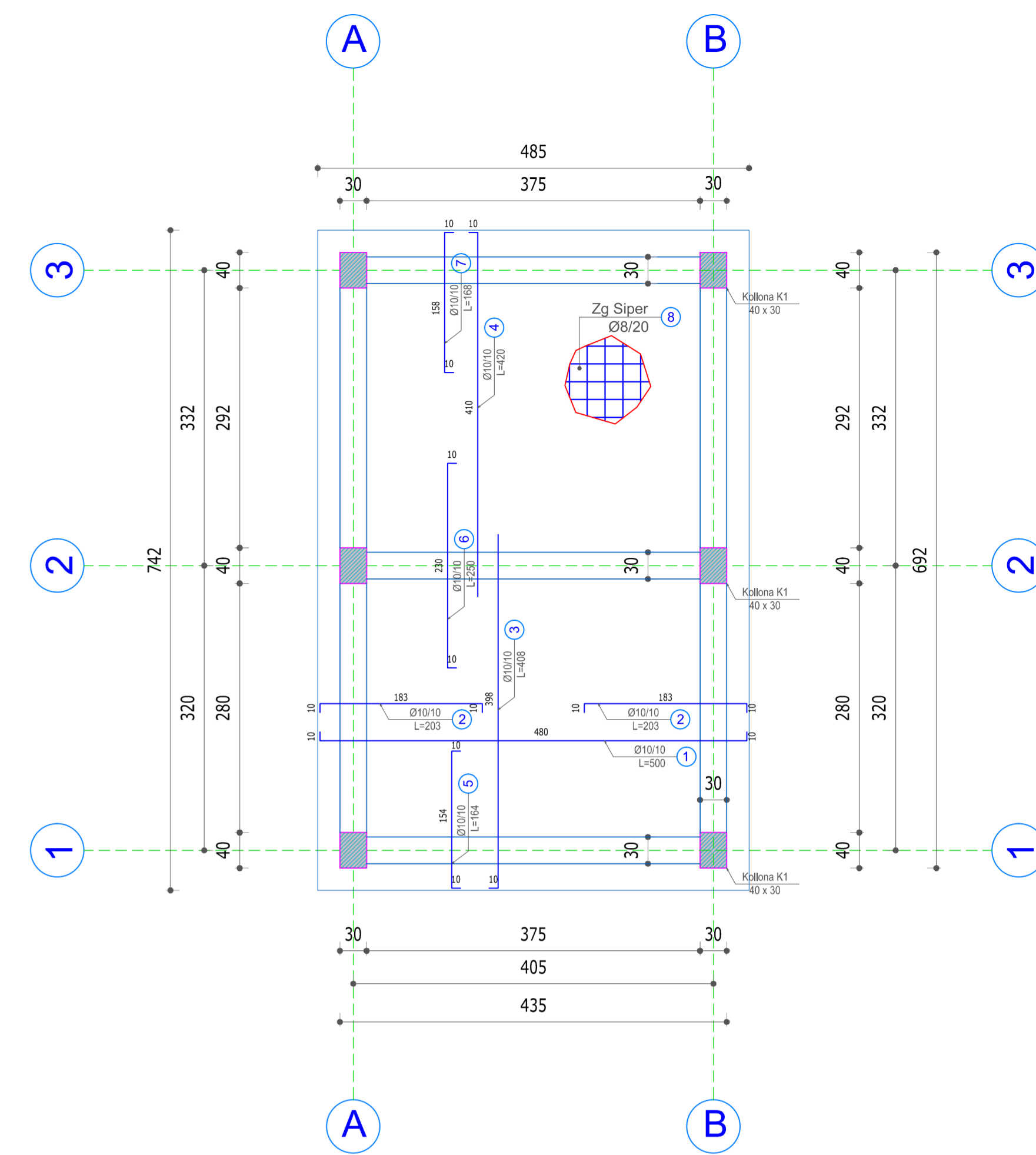

Armimi i Kollones

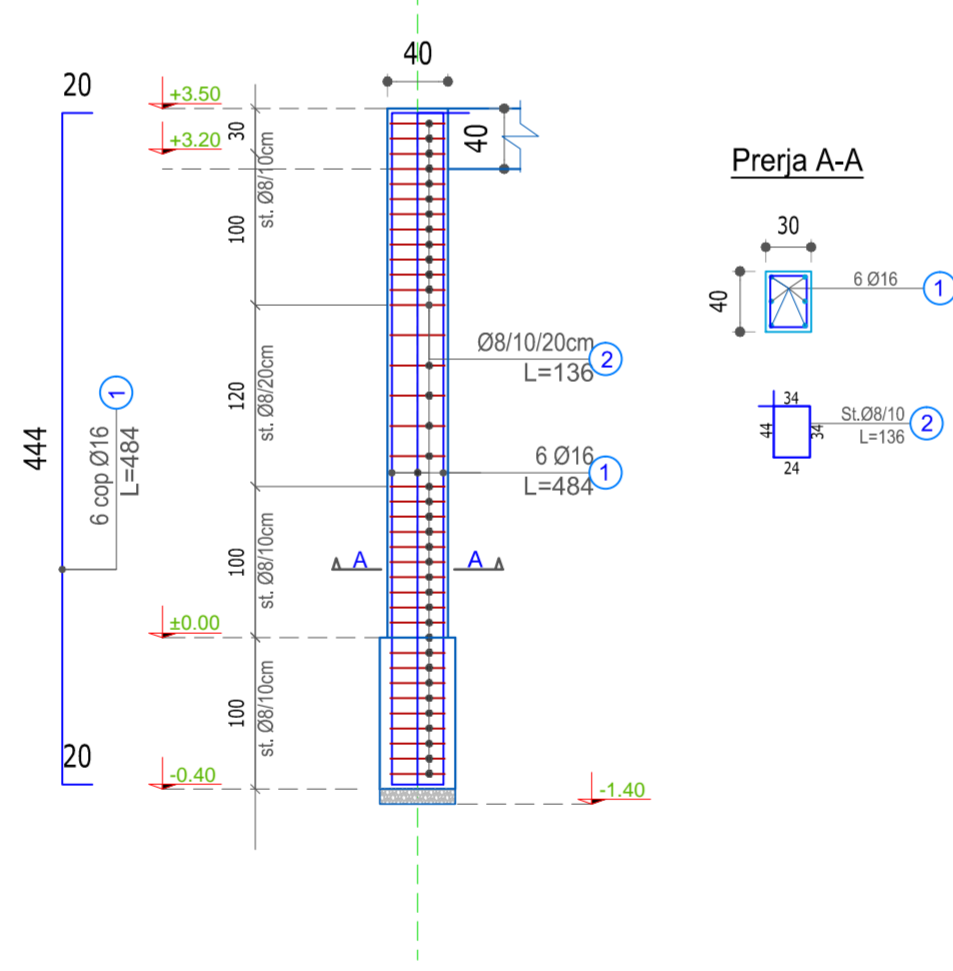

Tra T-1 (40x40) AKSI A dhe B

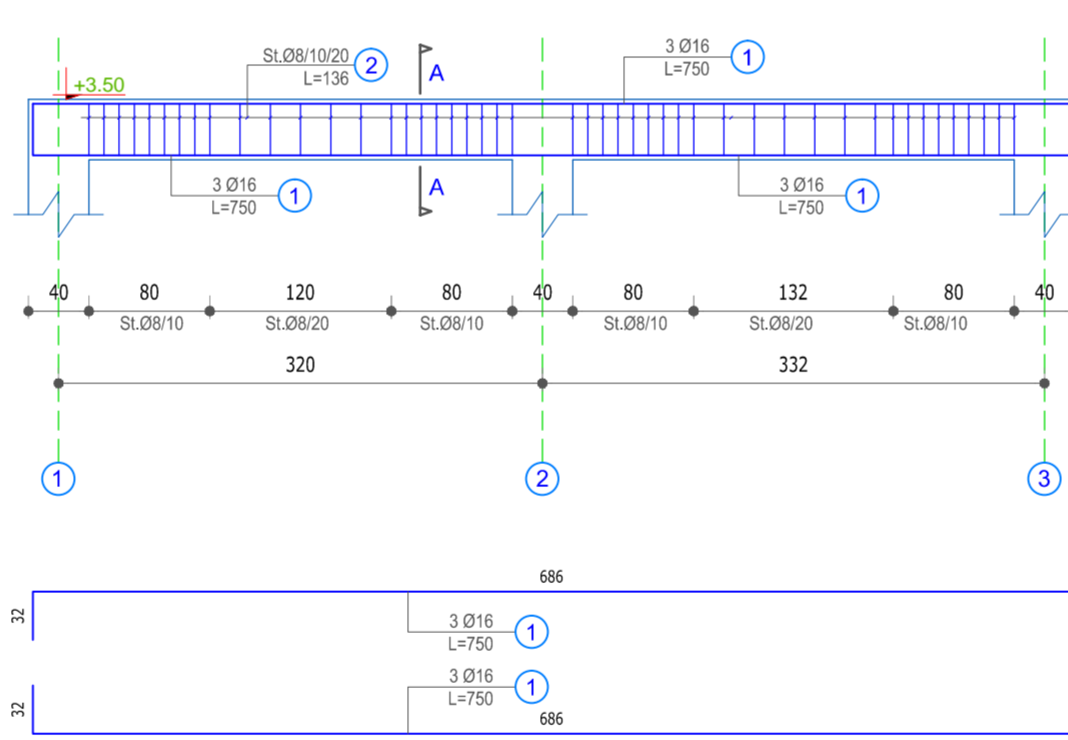

Prerja A-A

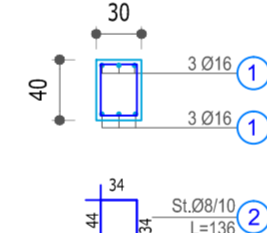

PLANI I AKSEVE DHE KOLLONAVE

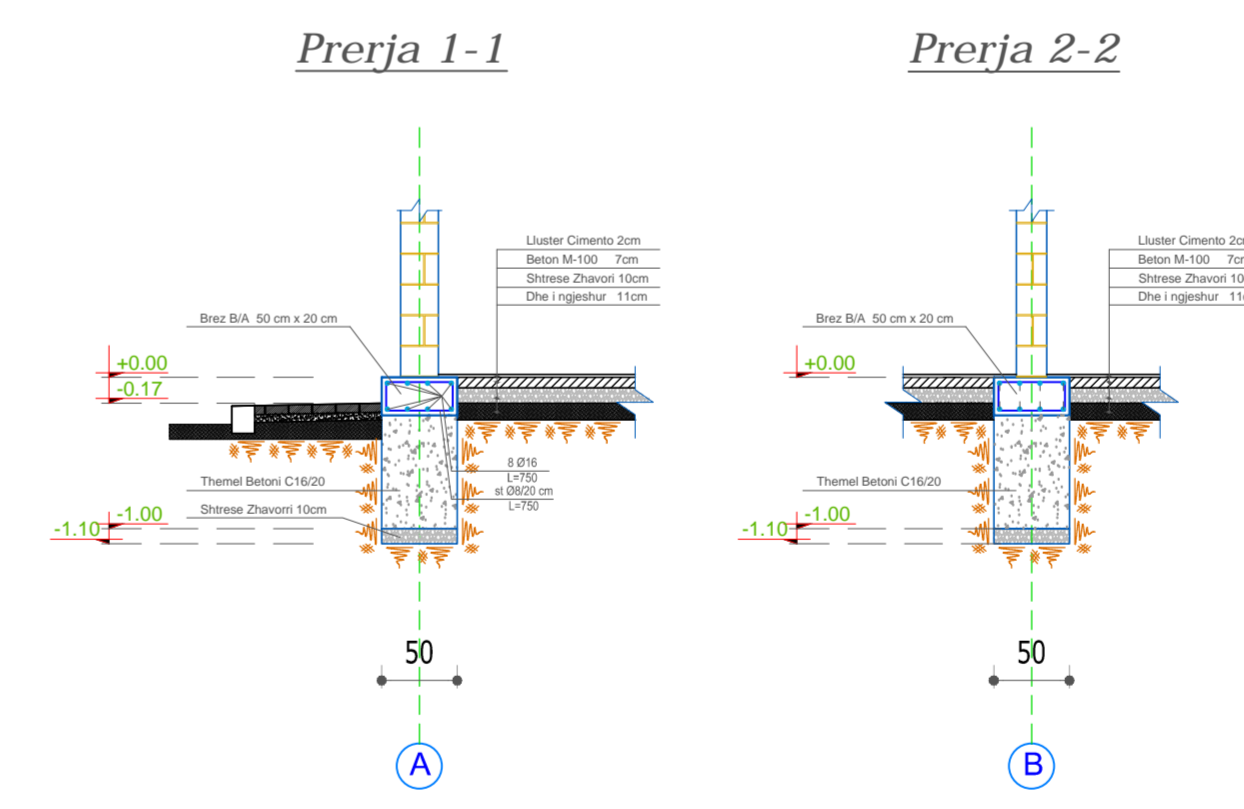

PRERJA A - A

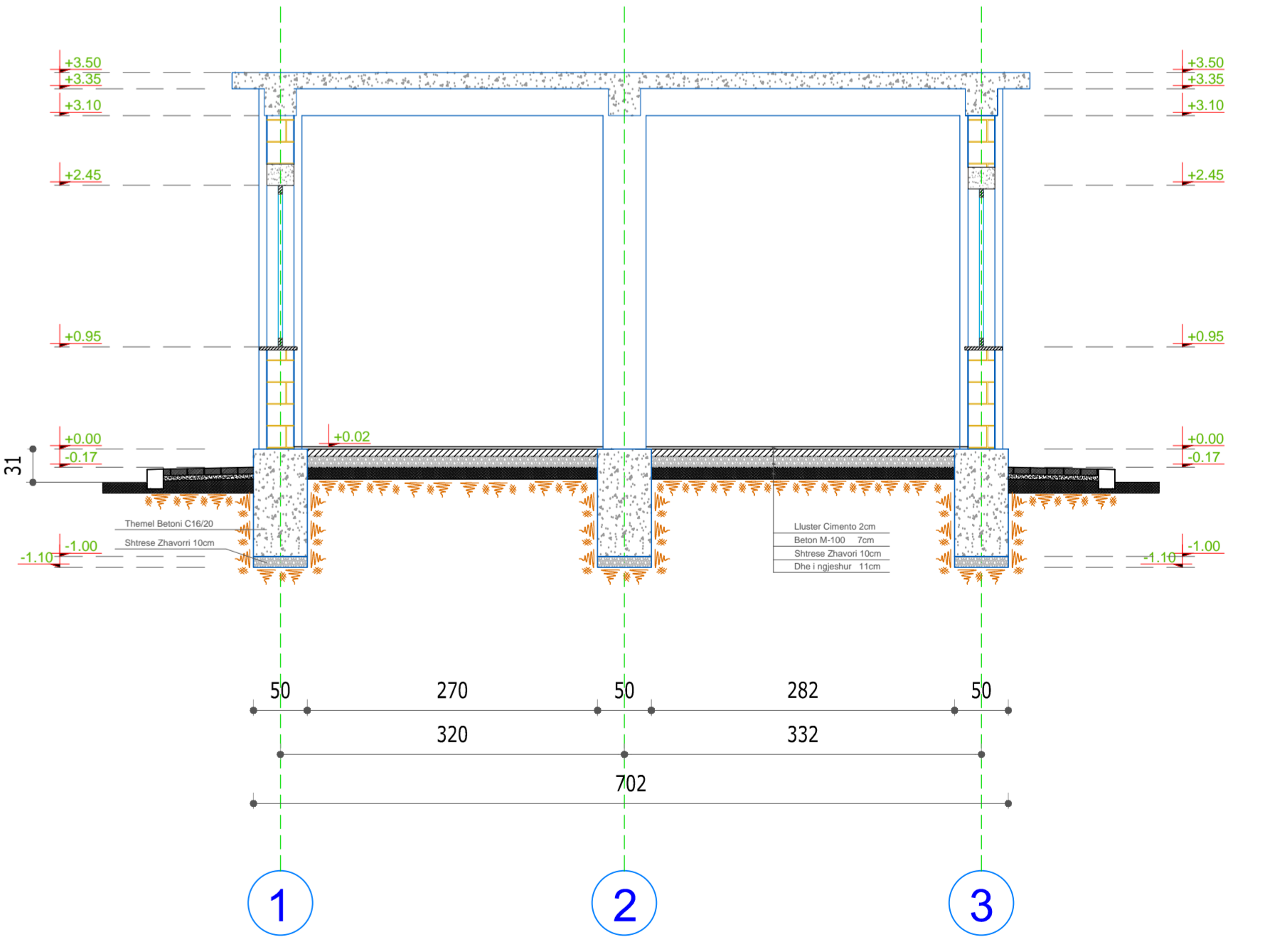

Brezi T(50 x 25)

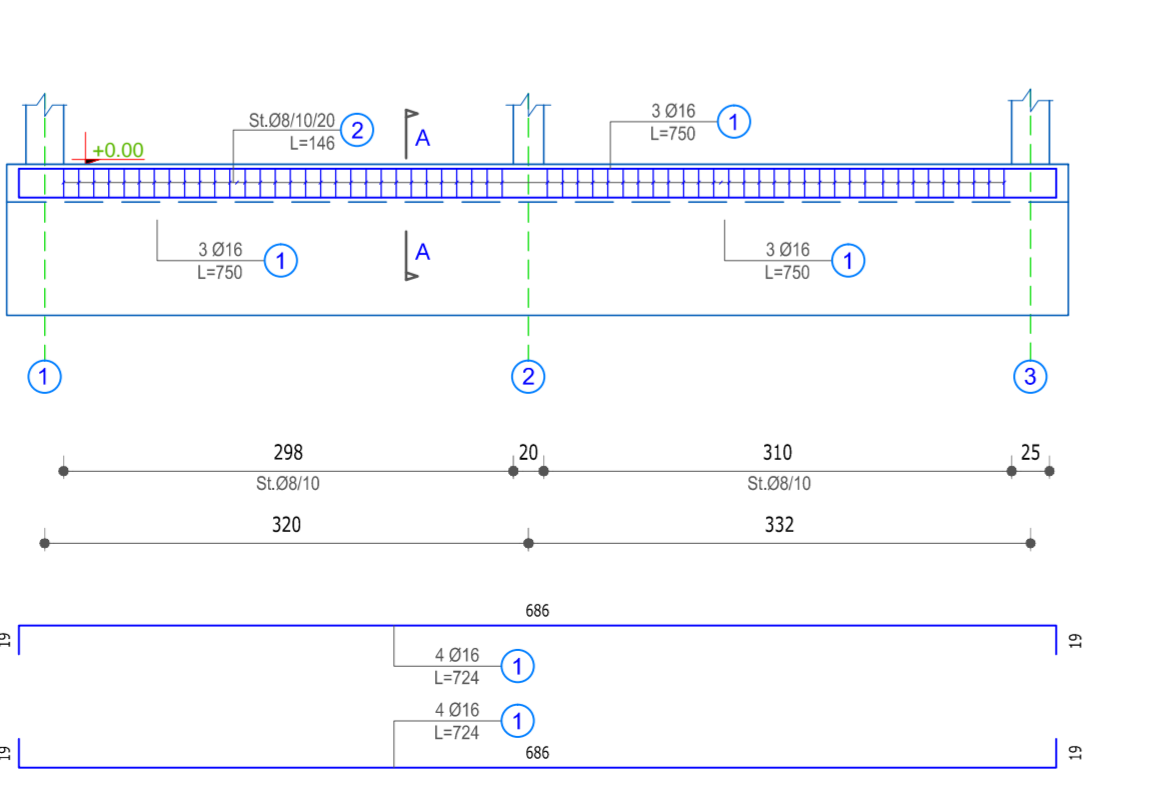

Prerja A-A

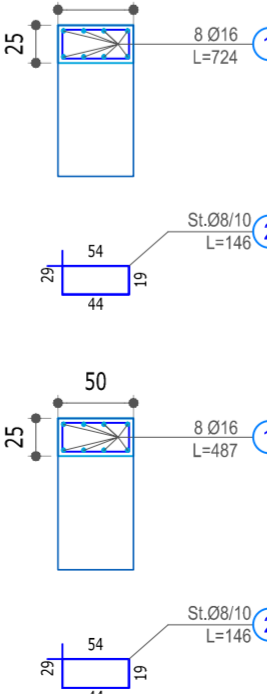

Tra T-1 (40x40) AKSI 1; 2 dhe 3

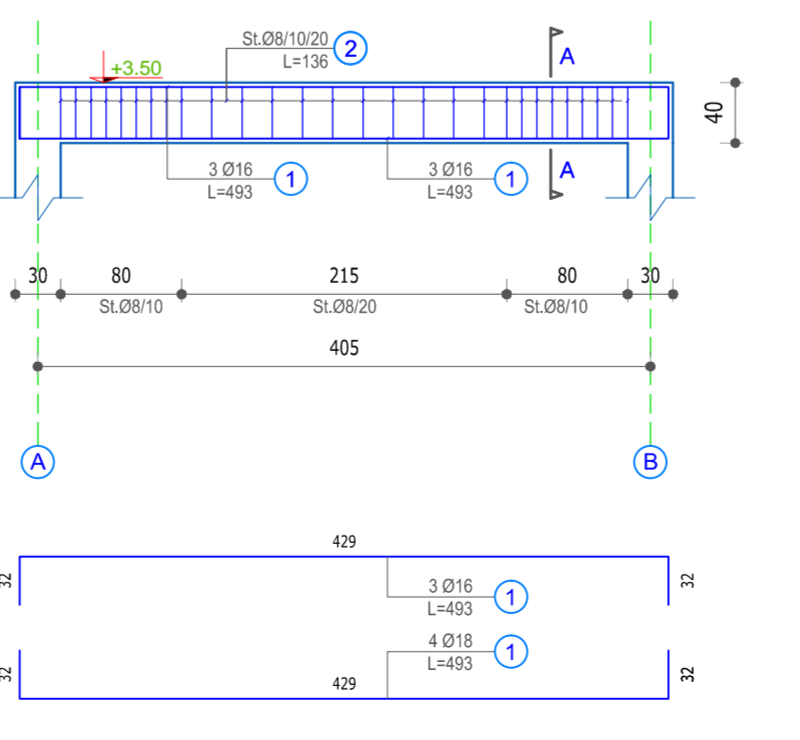

Prerja A-A

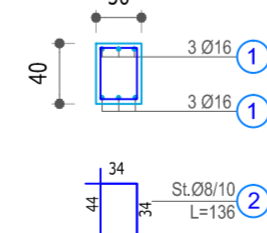

Prerja 3-3

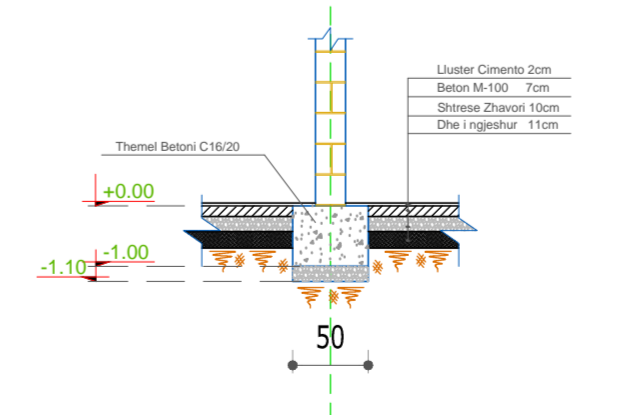

"SPHAERA" sh.p.k
PROJEKTIM
SUPERVIZION
KOLAUDIM

REPUBLIKA E SHQIPERISE
Ministria e Puneve Publike Transportit dhe Telekomunikacionit
DREJTORIA E PERGJITHSHME
E UJESJELLESIT DHE KANANIZIMEVE

RIKONSTRUKSION I RRJETIT TE UJESJELLESIT RAJONAL
TE ZONES SE DUMRESE
RRETHI ELBASAN

Titulli i vizatimit:
01. DEPO (SHPERNDARES) GASTARE
DHOMA E KOMANDIMIT
PLANIMETRI / ARMIMI / PRERJE TERTHORE

FAZA E PROJEKUT	PROJEKT ZBATIMI	DATA	PRILL 2013
NUMERI I VIZATIMIT	PL_D-01G	SHKALLA	1:50
Punoit	Ing. Ajkid Topore Ing. Hysni Ruka Ing. Andi Xhelepi	Perpunoit	Ing. Eljo Kamberaj



"SPHAERA" sh.p.k

PROJEKTIM
SUPERVIZION
KOLAUDIM

Rruga "QAZIM VATHI" nr 106 Tirane

Mobile 00355 69 20 38848
e-mail: ajkidtopore@sphaera.al
ajkidtopore@yahoo.com
website: www.sphaera.al

REPUBLIKA E SHQIPERISE
Ministria e Puneve Publike Transportit dhe Telekomunikacionit
DREJTORIA E PERGJITHSHME
E UJESJELLESIT DHE KANANIZIMEVE

RIKONSTRUKSION I RRJETIT TE UJESJELLESIT RAJONAL
TE ZONES SE DUMRESE
RRETHI ELBASAN

Titulli i vizatimit:

01. DEPO (SHPERNDARES) GASTARE
RRETHIMI I DEPOS

FAZA E PROJEKTIMIT PROJEKT ZBATIMI	DATA PRILL 2013	Ing. Ajkid Topore
NUMRI I VIZATIMIT PL_D-01H	SHKALLA 1:50	Punoi Ing. Hysni Ruka Ing. Andi Xhelepi Perpunoi Ing. Eljo Kamberaj

